



Specialist for Pumping Technology

INNOVATION
EFFICIENCY
QUALITY



RDP

Reciprocating Triplex & Quintuplex Plunger Pumps

More Than 65 Years Developing The Pumping Technology That Drives Progress

Ruhrpumpen is an innovative and efficient pump technology company that offers highly engineered, custom made solutions for the oil & gas, chemical, energy, nuclear, water and industrial markets. Ruhrpumpen offers a broad range of pump products that meet and exceed the requirements of the most demanding quality specifications and industry standards.

- Positive Displacement Pumps
- Single and Multi-Stage Between Bearing Pumps
- Vertical Multistage Pumps
- Single stage Overhung Pumps
- Full range of industrial products
- Submersible Pumps
- Magnetic Drive Pumps
- Decoking Systems
- Packaged Systems
- Fire Pump Systems



Introducing the RDP

Ruhrpumpen was one of the first companies in the world to produce reciprocating plunger pumps in full compliance with API 674 3rd edition, and ISO13710. What's more, with sound understanding we have manufactured pumps in accordance with many of the world's diverse oil industry specifications, including NACE MR01-75, Norsok, Shell ES135, GOST R, GOST K, GGTN.

When it comes to reciprocating plunger pumps no one knows them better inside and out. No one puts more expertise, knowledge or engineering into their products. Environmental sensitivity, dangerous chemicals, remote locations, difficult installations: whatever your pumping problem, we'd love to engineer you a solution. Our products are continually evolving.

Design Engineering

- First principles design analysis and mathematical modelling
- Created using state-of-the art CAD, CAE and CFD.
- Industry leading materials for long component life and increased resistance to the impacts of cavitation.



API 674
Latest Edition

Lifecycle Cost

- No compromise design for long pump life.
- Lowest levels of noise, vibration and wear.
- Designed for ease and speed of maintenance.

Benefits of the RDP

All pumps are fully ATEX compliant for hazardous and extreme environments. Castings are from leading British foundries and major parts are machined at manufacturing plants in Germany and the UK., Motors, couplings and seals are sourced from leading European suppliers. Designed and assembled in the United Kingdom, our reciprocating plunger pumps are specified for the most demanding high-pressure duties across the oil and gas and petrochemical industries.

Good technical selection. Experience is invaluable and with Ruhrpumpen you get this for free. For example, careful attention to the points below and overleaf will reward you with a reliable and efficient pump with long life and low cost of ownership.

Valve Design vs NPSHr

Hydraulic designs for low NPSHr are at the heart of the RDP Series. Each valve design and assembly is selected for the specific application.

- Max Velocity through the Valves 2.6 m/s.
- Max Velocity through the suction manifold 2m/s.



Plunger Speed

Optimal selection with advanced crankshaft and connecting rod dynamics combine to lower plunger velocity/acceleration. Lower plunger velocities reduce wear and helps to avoid issues such as cavitation.

Effect of Stroke to Connecting Rod Length Ratio

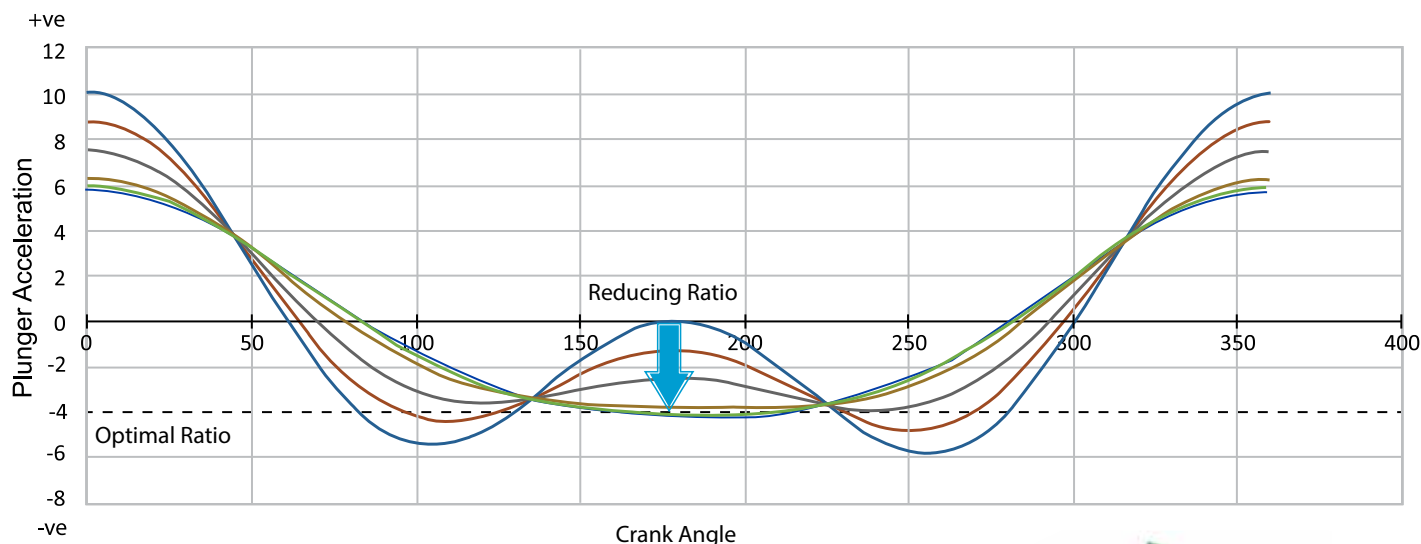

Hazardous Media (Seal Plans)

The environment is an increasingly sensitive issue and industry has a duty to protect personnel and control the escape of pollutants. The RDP is one of only a few pumps to feature a range of Emissions Containment Systems that offer up to near zero leakage of hazardous media to atmosphere.

Emission Control

Packing lubrication is an essential part of seal protection but is also used to provide a number of emission control solutions. These are selected considering the severity of the application. Gland leakage/spent lubricant can be simply directed to a flanged connection for disposal, or piped back to the pump inlet. More complex systems feature instrumentation to monitor seal condition, to alert if maintenance is required, or trigger safe pump shut down.

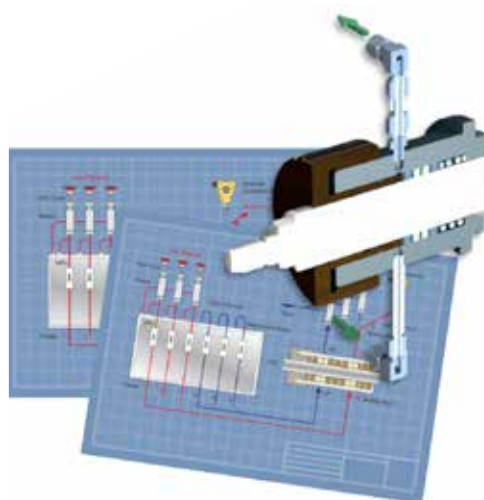

Zero Emission

For the most stringent applications we offer a gas tight sealed Distance Piece Chamber combined with our newly developed Energised Dual Seal technology, this ensures that no media or gas can escape uncontrolled into the environment.

While it is simple to seal the Distance Piece Chamber it is far less straightforward, yet equally vital, to isolate the drive components, particularly from hazardous gas ingress. The Energised Dual Seal is our solution to prevent this secondary means of escape.

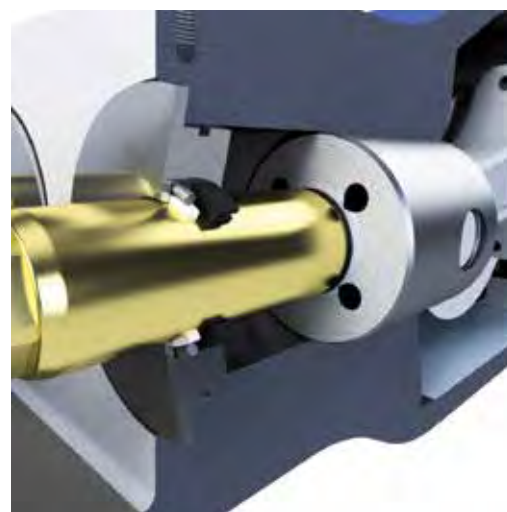

We Can Help You Choose Your Seal Plan

All the products described previously can be used in isolation or combined with any of our companion systems to provide a bespoke seal plan to suit your individual needs. The table overleaf shows just some of the Seal Plans available. Our engineers will work with you to create a system perfect for you.

RDP Benefits

- 1** SG Iron Crankcase – Optimised Design for sound insulation and minimal vibration.
- 2** Optional Sealed Rod Box for low emissions.
- 3** Access plugs for in situ maintenance of valves, seats and plungers.
- 4** Tapered Valve Seats for corrosive applications.
- 5** Integral valve assemblies for improved flow, low NPSHr and ease of maintenance.
- 6** Packing Lubrication Systems for increased Seal life and emission control.
- 7** Carbide hard faced Plungers for increased life.
- 8** Rod box threaded drain port for drainage to safe area.
- 9** Titanium Nitride coated Distance Pieces for low friction with increased Seal life and corrosion resistance.
- 10** Direct mountings for overhead Motor and Accessories.
- 11** IP65 Filler Breather.
- 12** Solid cast Rear Cover for reduced noise levels.
- 13** High strength nitrided and ground Wrist Pins with specialised alloy bushings for increased bearing life & high inlet pressures.
- 14** Tapered Roller Bearings for high rod loads.
- 15** Specialised alloy connecting rods.
- 16** Nitrided Crankshafts for long life.
- 17** Multiple Seal plans with option for back pull out of Seals and Packings.

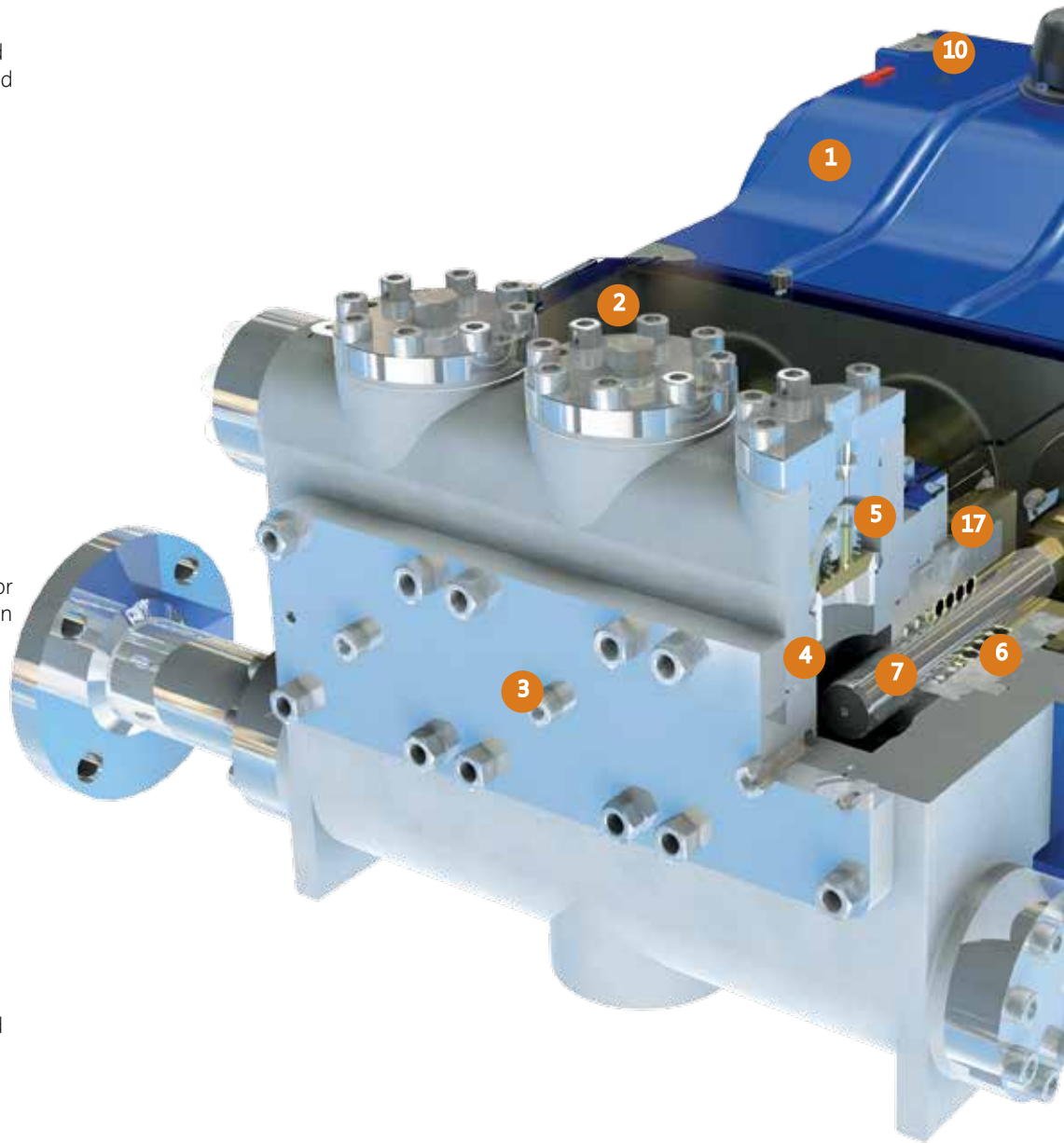

Images for general arrangement use only, not certified for construction.

PERFORMANCE DATA

Max Capacity	366.5 m ³ /hr / 1611.0 US gpm
Max Discharge Pressure	1000 bar / 14500 psi
Temperature	-40 °C up to 200 °C / -104 °F up to 392 °F.
Max Pump Speed	450 rpm (see note 3)
Pipe Size	25-200 mm (1-8")

Note:

1. For applications outside this range, please contact a Ruhrpumpen representative.
2. Max. Flow and Max. Pressure cannot be met at same time.
3. Maximum speed allowed by API674.

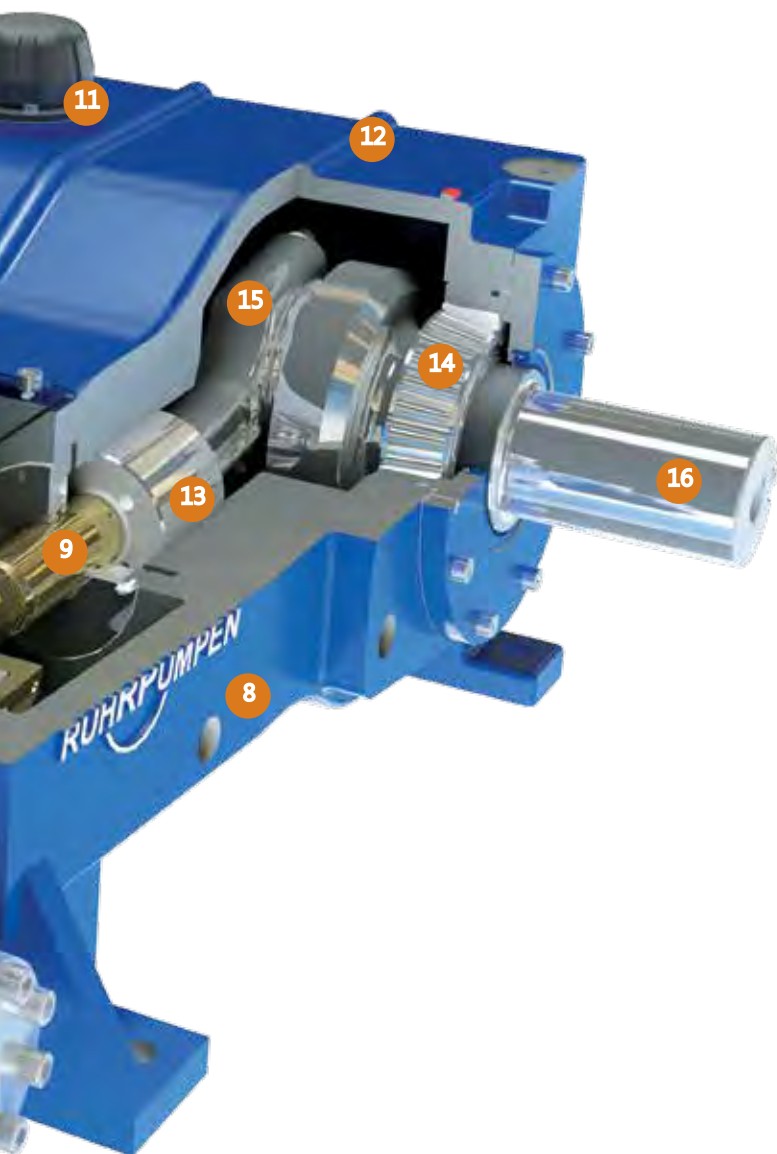

DESCRIPTION

The RDP series of Reciprocating Plunger Pumps is suitable for handling most liquids for Oil & Gas and Industrial applications.

- A variety of sizes are offered in Triplex and Quintuplex format.
- All are designed in accordance with API674 3rd edition and ISO13710.
- Easily accessible service points reducing maintenance time.
- Robust design for low noise and vibrational characteristics.
- High duty efficiency.
- Extensive range capability.
- Design life 20 years.

BROAD APPLICATION RANGE

- Methanol injection
- Glycol circulation
- Sea water injection
- Produced water disposal
- Reverse osmosis (seawater desalination)
- Water treatment, production and jetting
- Hydrocarbon – Condensate
- Closed drain pumps
- Slops injection
- Boiler feed
- Fertiliser – Carbamate & Ammonia
- Steel plants – high pressure descaling
- Blow Out Preventer (BOPV) actuation
- Flowline circulation & Pipeline pigging

MATERIAL OF CONSTRUCTION

- Crankcase made in ductile iron with customer specific paint finish.
- Wetted parts can be made from a wide range of alloys incl NACE and NORSOK compliance.
- All materials provided are high quality and NDT can be tailored to meet the project's requirements.

DESIGN FEATURES

- Excellent noise and vibration characteristics < 85dB(A).
- 95% volumetric and 90% mechanical efficiency, exceeding API standards.
- Stuffing box can be removed without pump disassembly.
- Spring loaded, auto adjustment braided compression and chevron packing, minimises leakage.
- Valves in cartridge, easy removal and replacement configurable for drives, lubrication and skids.

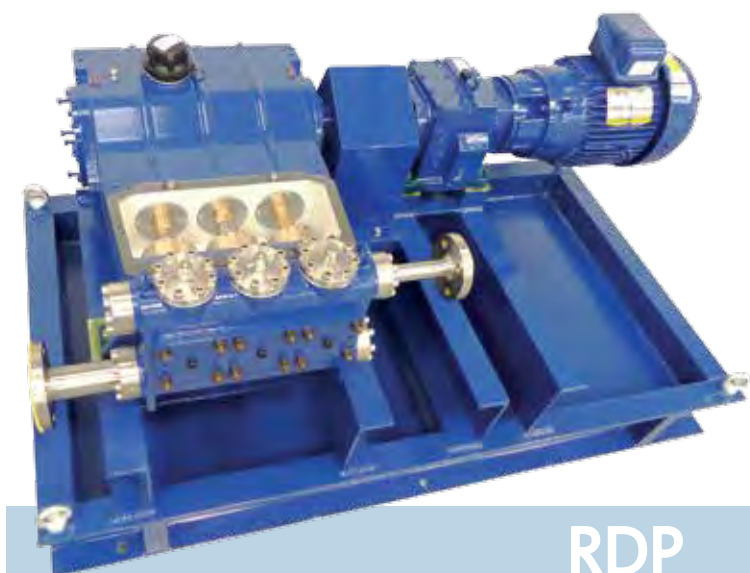

RDP
CYLINDRICAL SHAFT END

Performance Range

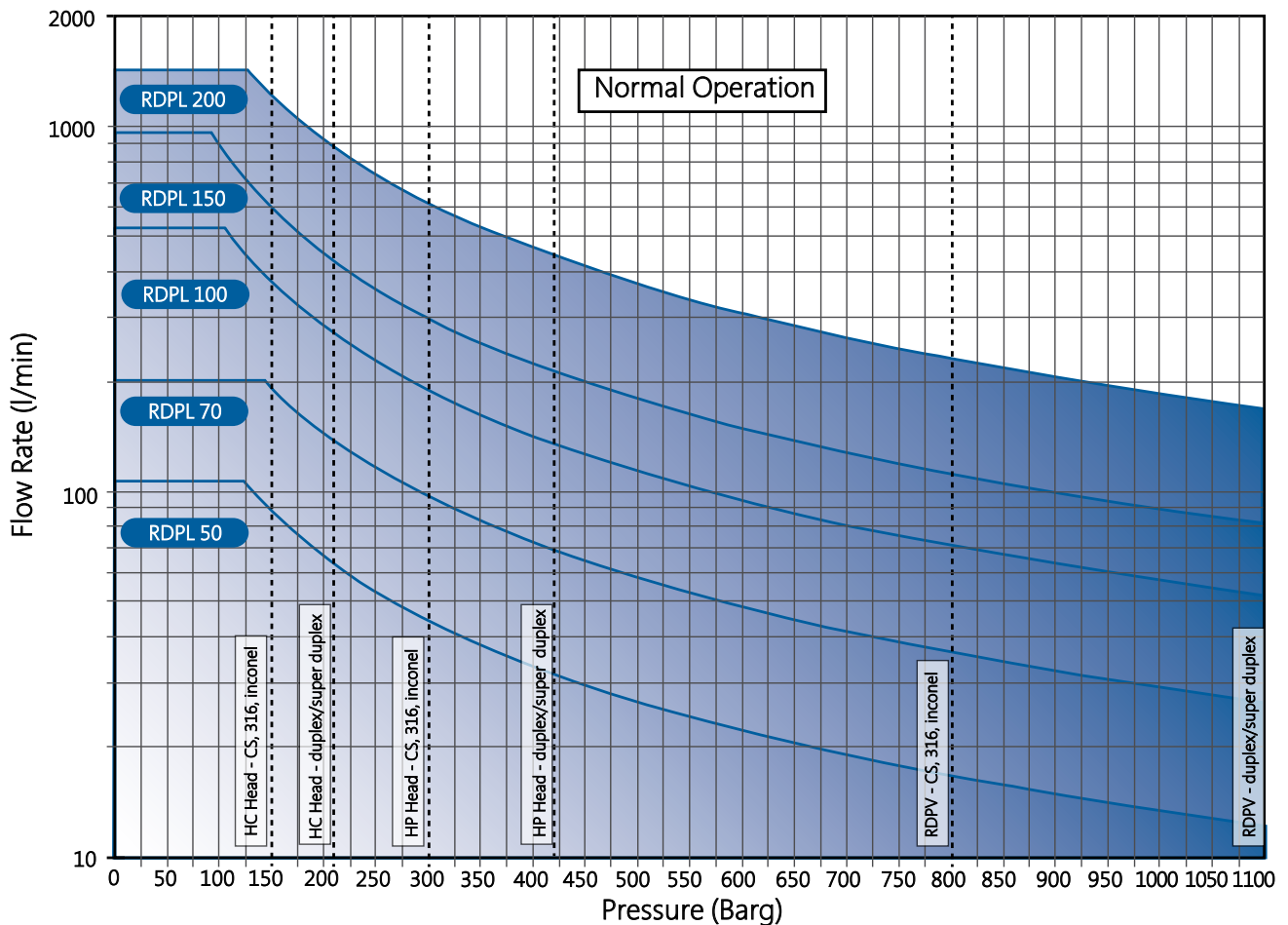

Package Options

- Can be manufactured to meet project specific specification such as Norsok, ASME, Russian CU TR, Statoil TR1655.
- Dampeners, PSV's and instrumentation can mount direct to Pump Head.
- Motor can mount direct to top of crankcase for compact offshore footprint.
- ATEX compliance for electrical and non electrical machinery.
- Package condition monitoring.
- Fugitive Emissions Seal Systems. with condition monitoring.
- Various seal and power end lubrication options.
- Electric motor.
- Diesel engine.
- Hydraulic motor.
- Variable speed drive.
- Various transmission options including Gearbox / V-belt drives.

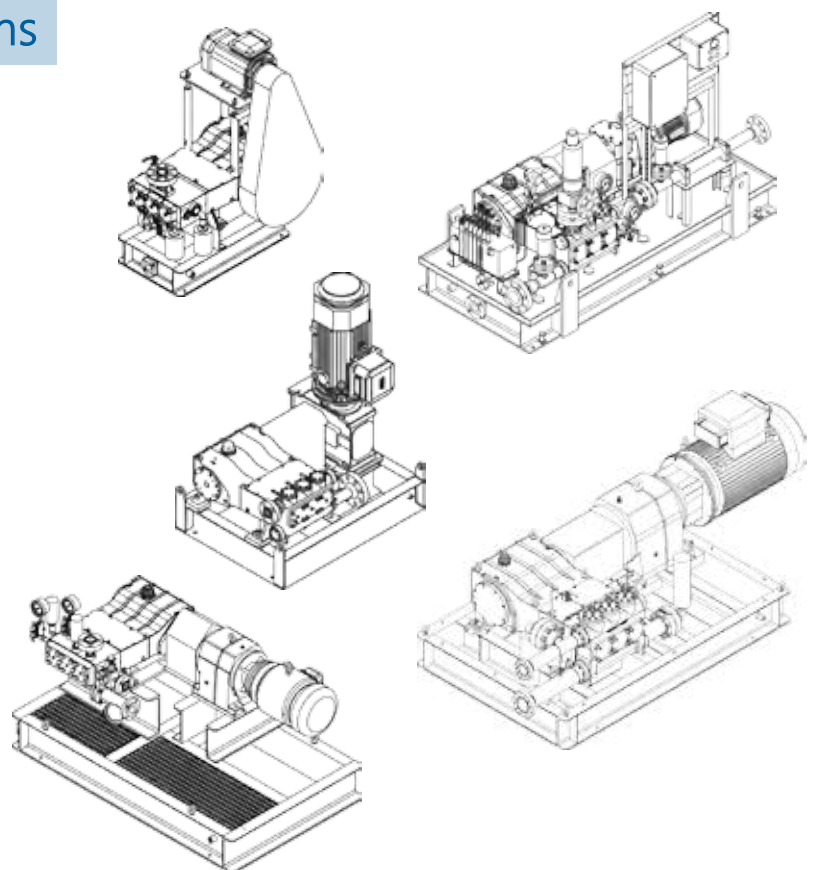

Other Ruhrpumpen Products



Vertical Barrel Pump

Low NPSH "Shockless Entry" first stage impeller (single or double suction), Single or multi-stage. Standard construction materials according to API latest edition (type VS6).
 Condensate, Power plants, Municipal, Hydrocarbons, Pipeline, and Refineries.



Sump Pump

Single Stage single suction vertical centrifugal pump, volute type case, flanged and threaded discharge, cast iron casing, flexible coupling.
 Sump Drainage, Flood Control, Air Wash Systems, Power Plants, Chemical Industry, Municipal Systems, Water Treatment, Process Plants, and Sewage Lift Stations.



Vertical Turbine Pump

Multistage vertical centrifugal pump with diffuser type bowl, semi-open / enclosed impellers, cast iron bowls, counterclockwise rotation viewed from coupling end.
 Deep Well, Irrigation, Cooling Tower, Sump, and Condensate Pumps.



Volute Casing Centrifugal Pump

Axially split, horizontal single or two stage, double volute casing, double suction, closed impeller. Heavy duty process design according to API 610 latest edition (type BB1).
 Pipeline Service-Mainline and Booster, Oil Extraction, Refinery, Chemical, Petrochemical, Metallurgical Industry, and Power Stations.



Vertical In-Line Pump

Vertically (radially) split case, centerline supported with an overhung impeller.
 Air Conditioning Systems, Condensed Water, Ice Water, Service Water, Fire Systems, Ocean Water and Building water supply systems.



Heavy Duty, Single Stage, ANSI Chemical Process Pump

Single stage horizontal centrifugal pump, radially split casing with flanged connections, horizontal end suction and centerline top discharge.
 Petrochemical, Oil & Gas, Steel Industry, Automotive, Food processing, Power generation, Pharmaceuticals, Water treatment, General process.

With every project you can count on **QUALITY, SERVICE, EXPERTISE, INNOVATION** and **COMPETITIVENESS**.
 Because we have a commitment with each customer, the community and the world.
 We are Ruhrpumpen the specialist for pumping technology!



RUHRPUMPEN PLANTS

-  USA, Tulsa
-  MEXICO, Monterrey
-  BRAZIL, Rio De Janeiro
-  ARGENTINA, Buenos Aires
-  GERMANY, Witten
-  EGYPT, Suez
-  INDIA, Chennai
-  CHINA, Changzhou
-  UK, Lancing
-  RUSSIA, Moscow

More Information:

Ruhrpumpen UK Ltd:
22 Commerce Way, Lancing Business Park,
West Sussex. BN15 8TA.
T:+44 (0)1273 956410
E: salesuk@ruhrpumpen.com

