



Specialist for Pumping Technology



CRP-M

**Centrifugal Pump with Permanent Magnetic Drive
according to DIN EN 2858 and DIN EN ISO 15783**

CRP-M

Centrifugal Pump with Permanent Magnetic Drive

+75 years developing the pumping technology that drives progress

Ruhrpumpen is an innovative and efficient pump technology company that offers highly engineered, custom made solutions for oil & gas, chemical processing, power generation, industrial applications and water.

Implementation of cutting-edge technology and world-class engineering, combined with our unique vertically integrated structure, allows Ruhrpumpen to design complex technical solutions, creating the most robust and powerful pump systems in the marketplace.

Our broad product line complies with the most demanding quality standards and industry specifications such as **American Petroleum Institute (API)**, **American National Standards Institute (ANSI)**, **Underwriter's Laboratories (UL)**, **Factory Mutual (FM)**, **National Fire Protection Association (NFPA)**, **ISO** and **Hydraulic Institute**.

Products Include:

- Single stage overhung pumps
- Vertical in-line pumps
- Single and multi-stage between bearing pumps
- Multi-stage vertical pumps
- Reciprocating plunger pumps
- Sealless magnetic drive pumps
- Fire protection systems
- Pitot tube pumps
- Hydraulic decoking systems
- Horizontal pumping systems

CRP-M Pumps

With the new design range of the CRP-M Ruhrpumpen expands their product range also for the Chemical Industry. The hydraulic of this new pump range is completely new calculated and designed, therefore high efficiencies and low NPSHr values can be achieved. The CRP-M pump range is equipped with a permanent magnetic drive in accordance with DIN EN 2858 and DIN EN ISO 15783 and strikes new paths especially for the design of the Journal Bearings, Internal Flows and Pressures, Magnetic Drive System and Axial Thrust Balancing.

As a 100% leakage free pump the CRP-M avoids high maintenance costs and usage of mechanical seals. It is also the best option for taking care of the environment and meets the requirements of the TA-Luft specification (German Technical Instruction on Air Quality Control).

So far 33 hydraulics are available for range of the CRP-M pump, so almost all customer requirements are met. The CRP-M pump is built with the latest engineering techniques and tools such as 3D Modeling, Finite-Element Analysis and CFD-Simulation – Computational Fluid Dynamics – to assure our customers of the best product quality. It is our target to extend our pump range above the DIN EN pump sizes up 3500 m³/h.



Ruhrpumpen is your single source supplier

- Original Equipment
- Spare parts
- Installation and startup support
- Repair and maintenance
- Engineering, training and consulting
- Reverse engineering

Benefits of our pumps

- Proven reliability
- High efficiency designs ensure lowest operating cost
- Robust design allows for long system life with minimal maintenance
- Optimized total cost of ownership



Standard Material

INDIVIDUAL PARTS	MATERIAL	MATERIAL
Volute Casing	1.0619 (Carbon Steel)	1.4408 (316 AUS)
Impeller	1.4408 (316 AUS)	1.4408 (316 AUS)
Containment Shell	2.4610 (Hastelloy C)	2.4610 (Hastelloy C)
Inner Magnet Rotor	1.4571 (316 AUS)	1.4571 (316 AUS)
Pump Shaft	1.7225 (AISI 4140)	1.4571 (316 AUS)
Drive Shaft	1.7225 (AISI 4140)	1.7225 (AISI 4140)
Intermediate Lantern	1.0619 (Carbon Steel)	1.0619 (Carbon Steel)
Bearing Bracket	1.0619 (Carbon Steel)	1.0619 (Carbon Steel)

*Other material combinations like 2.4686, 2.4685, 2.4660 and 3.7035 are also available.
Other materials on demand.*

CRP-MO

With oil lubricated anti-friction bearings (O)



Characteristics

- 1 Volute Casing Pump**
Designed for 16 bar at 120°C, foot mounted.
- 2 Casing Gasket**
Only two static gaskets on casing and containment shell. The gaskets are certified to TA-Luft specification.
- 3 Renewable Wear Rings**
Full complement of renewable casing and casing cover wear rings are standard.
- 4 Journal Bearings**
Spherical design for universal, multiple applications. Axial and radial bearings made of "pure" Sintered Silicon Carbide (SSiC) in standard design.
- 5 Axial Thrust Bearings**
Due to hydraulic measures the axial thrust will be controlled over the complete operating range.
- 6 Internal Flushing System**
By careful design of internal flush flow passages, bearings and magnetic drive receive optimal lubrication across the pump curve up to 1.5 x Q_{opt}.
- 7 Inner Magnet Rotor**
With an additional rub ring area on the bearing bush housing.
- 8 Internal Filter System**
The self cleaning internal filter is located on the casing cover and prevents unacceptable solid particles from entering through the internal flow system into the magnetic drive and journal bearings. The internal filter is positioned at the highest internal pressure. A control of the operation is possible via a pressure control.
- 9 Ceramic Insulation and Heating Barrier**
To avoid a heat transfer from the end of the containment shell to the front side of the drive shaft and also to the end of the outer magnet rotor, the bottom of the containment shell is insulated with a high temperature-resistant ceramic (1200°C=2192°F). Also with an additional thermal barrier (option), cast to the bearing bracket, the temperature rise is dissipated over the bearing bracket flange in the cooling fins. This thermal barrier prevents excessive heat transfer to the anti-friction bearings, thereby extending bearing life.

- 10 Intermediate Housing**
With a non-sparking rub ring and a non-sparking ring as fit-up aid for assembly/disassembly.
- 11 Bearing Bracket**
Life time greased lubricated anti-friction bearings as standard. Oil lubricated anti-friction bearings (option) are possible. Increased bearing bracket stiffness guarantees low vibration levels, ensuring safety and reliability.

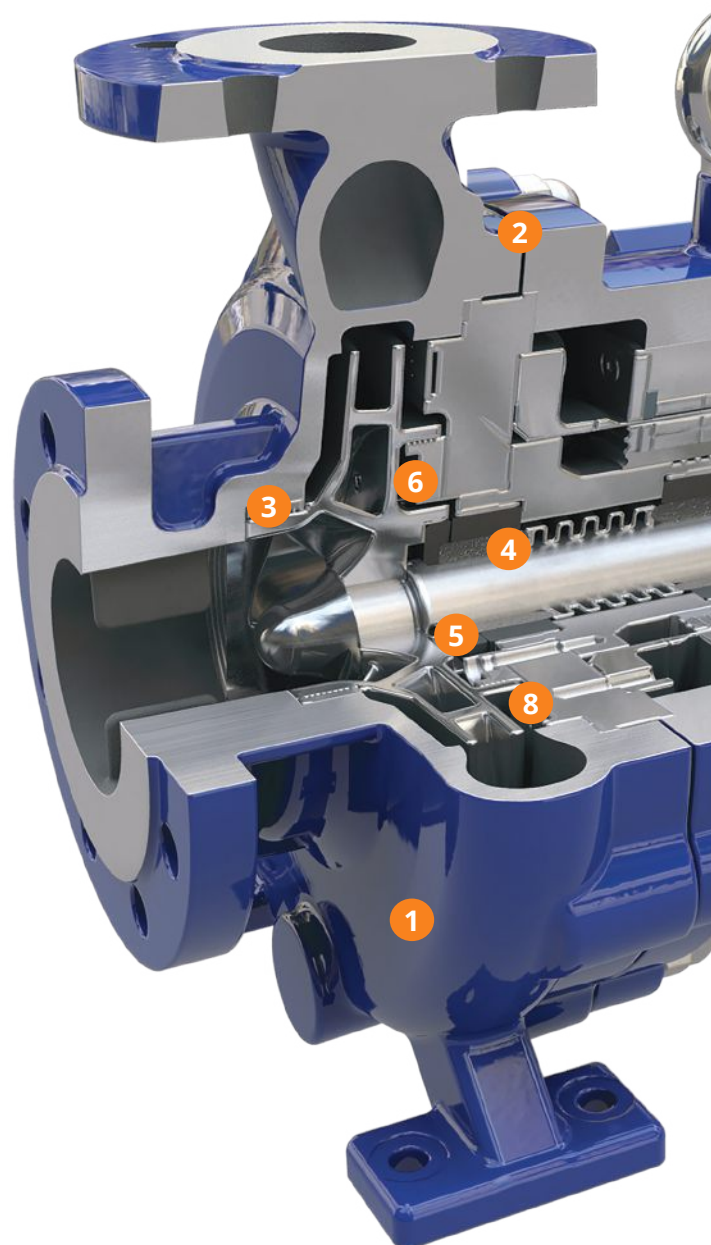

12 Vibration/Temperature

Bearing bracket and intermediate lantern are provided with pre-determined permanent locations to inspect vibration and oil/bearing temperature.

13 Containment Shell

The containment shell separates 100% leakage-free the product chamber from the atmosphere and creates a static sealing between the inner and outer magnet rotor. The containment shell is designed in standard for 16 bar at 250°C. The containment shell is self-venting and fully drainable.

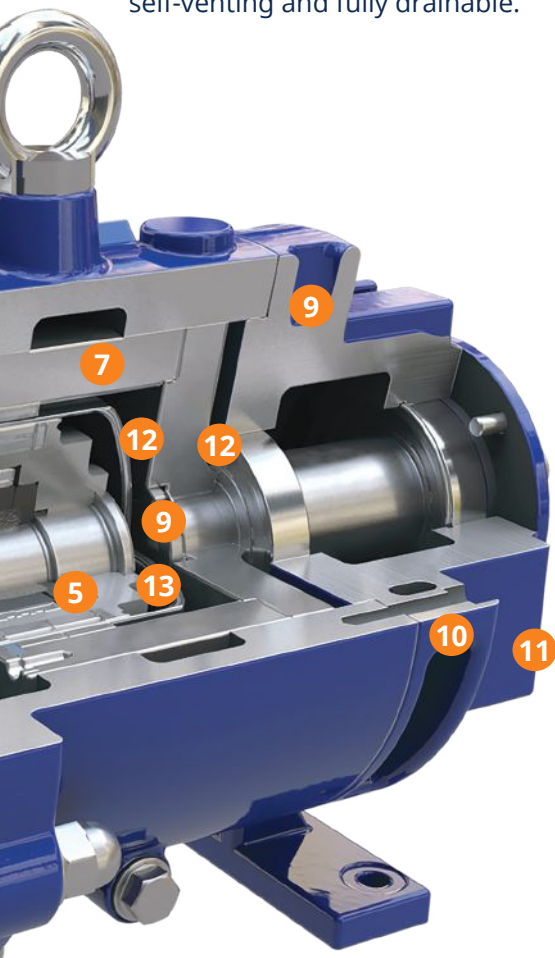

DESCRIPTION

Centrifugal Pump with Permanent Magnetic Drive, designed to meet full DIN EN 22858 and DIN EN ISO 15783 pump standards. The anti-friction bearings are available with extended dimension (E) between the bearings to exceed their life time and also in oil lubricated design. Horizontal single stage, foot mounted casing and intermediate lantern, back-pull-out, radially split, end suction, top discharge, single suction.

QUALITY ASSURANCE

All Ruhrpumpen facilities are certified according to ISO 9001.

PERFORMANCE DATA

Capacity	up to 500 m ³ /h	up to 2,200 gpm
Head	up to 215 m	up to 705 ft
Design Pressure	16 bar at 120°C	232 psi at 248°F
Temperature	-120°C to 450°C	-184°F to 840°F

Notes:

For pump operations outside this range, please contact a Ruhrpumpen Representative.

PUMPING OF

- Acids
- Bases
- Hot transfer oils
- Liquid gases
- Hydrocarbons
- Aggressive, explosive and toxic liquids

FIELDS OF APPLICATION

- Chemical and Petrochemical Industry
- Tank farms
- Liquid gas industry
- Refrigeration- and heat technology
- Power plant technology
- Galvano technique

Special Technique and Design Features

JOURNAL BEARING DESIGN

The axial and double radial Journal bearing made of “pure” Sintered Silicon Carbide (SSiC) in standard design is designed with the following features:

- Spherical locking sleeve for axial and radial centering.
- Bearing sleeves with a sphere for axial and radial centering.
- Radial centering of the bearing sleeves in the axial thrust bearings in the same material (SSiC/SSiC) results in the same expansion factor over the complete temperature application range.
- Bearing bushes with double interference fit assembly to avoid axial torsion and radial displacement.
- No edge loads induced by radial loads at the surface of the bearing sleeves and the bearing bushes.

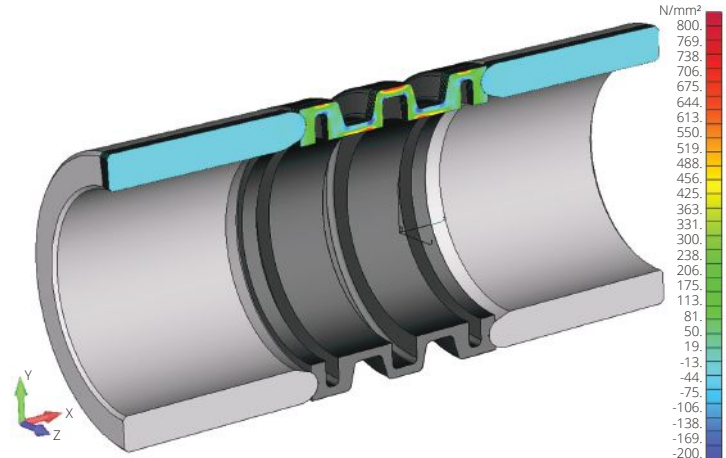

The geometry of the locking sleeve has been calculated with the help of the finite element method (FEM). The exercise was to guarantee the power transmission by the initial load between the rotating parts with different thermal characteristics of the materials (different expansion coefficient between SSiC and stainless steel 1:4), at temperatures up to 350°C (662°F).

Due to the geometry the pre-loaded locking sleeve compensates the differences of the linear expansion caused by the material and thermal between “pure” Sintered Silicon Carbide (SSiC) and the pump shaft made of stainless steel in axial and radial direction. The centering of the rotating bearing parts is always guaranteed.

INTERNAL FLOWS AND PRESSURES

A reliable and well-defined pressurization within the flushing system for the magnetic drive and the journal bearings is extremely important

for the operation and integrity of the pump. The pressure for both the magnetic drive and internal bearing flush flows is taken from the point of highest pressure location (2) and is fed directly into the magnetic drive and the journal bearings.

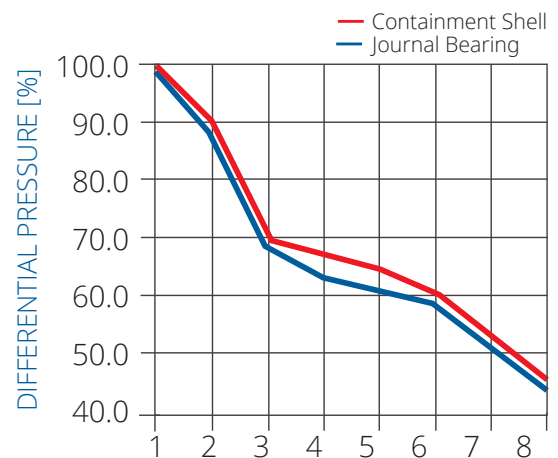

INTERNAL FLOWS AND PRESSURES

The well-defined pressurized internal flush flow into the journal bearings (3) guarantees the necessary heat dissipation and the lubrication within these bearings (4). It is of high importance, that the internal flush flow (5) is fed via a drilling system from a high-pressure point to a low-pressure point (7) into the drilled shaft. The internal flush flow in the front bearing bush is returned by the axial thrust bearing into the pressure chamber (8) behind the impeller.

The well-defined pressurized internal flush flow, which is fed into the area of magnetic drive, guarantees the necessary heat dissipation of the magnetic losses.

Both these internal flush flows join in the drilled shaft (7) and are also fed by the drilling system into the pressure chamber (8) behind the impeller. This guarantees that this optimized flushing system prevents the vaporization of the product in the pump. The internal flush flow will be fed by the impeller balancing holes from a location of higher pressure into the blades of the impeller.

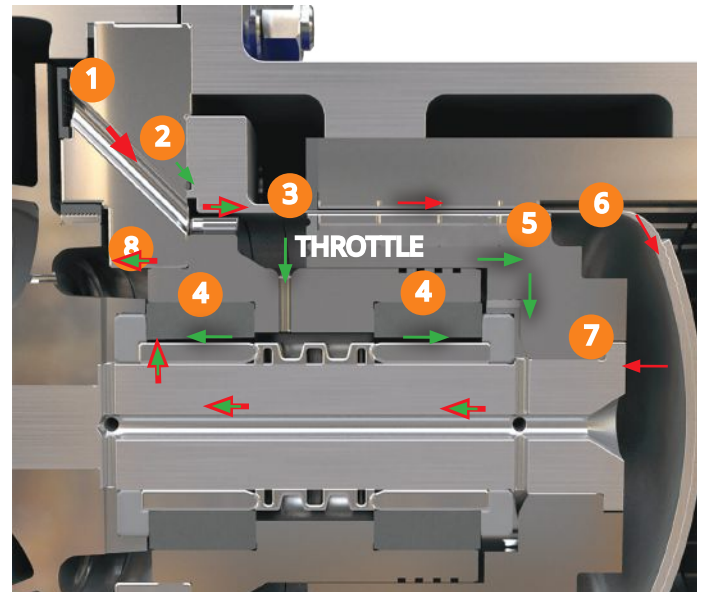

MAGNETIC DRIVE SYSTEM

The magnet drive system transmits the torque without slip by a permanent magnetic field. The magnets made of thermally stable samarium cobalt material (Sm2Co17) are suitable in standard for a maximum allowable operating temperature of 250°C (300°C). Special magnetic drive systems based also on Sm2Co17 material are suitable for an operating temperature up to 450°C.

The central assembly of the magnetic drive system over the journal bearing avoids moment loadings on the journal bearing, thus avoiding eccentric loading of the inner magnet rotor during start-up and shut-down.

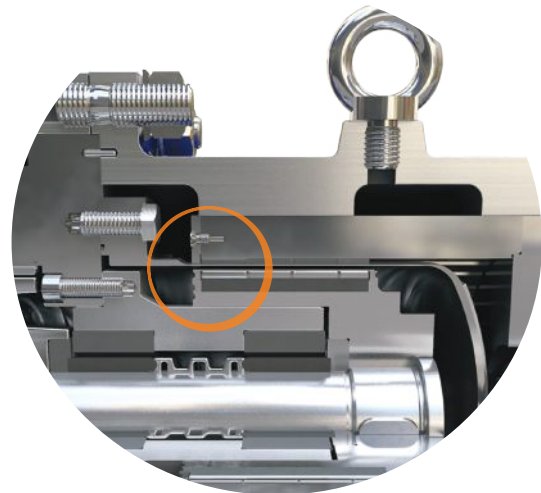

AXIAL THRUST BALANCE

By optimizing the annular areas within the internal flush system the axial thrust will be minimized over the complete operating range up to $Q_{opt.} \times 1.5$. The residual thrust stabilizes the pump rotor axially and is absorbed by the axial thrust bearings. These measures ensure, that products close to the vapor pressure can be handled without limitation, without the risk of vaporization at the axial thrust bearings.

Special Configurations and Optional Features

SECONDARY CONTROL SYSTEM

The CRP-M pump in the standard design is equipped with a single containment shell, rated for 16 bar and 250 °C.

The intermediate housing, as a secondary pressure casing, is rated for the same pressure as the pressure casing. The altern magnet rotor is equipped with a labyrinth system. When a secondary control is required, the labyrinth system, designed as a throttle, rotating in opposite direction restricts the escaped liquid in the intermediate housing in case of a containment shell failure.

The presence of liquid or the increased pressure can be detected by a monitoring system. The liquid drainage can be controlled through the draining pipe.

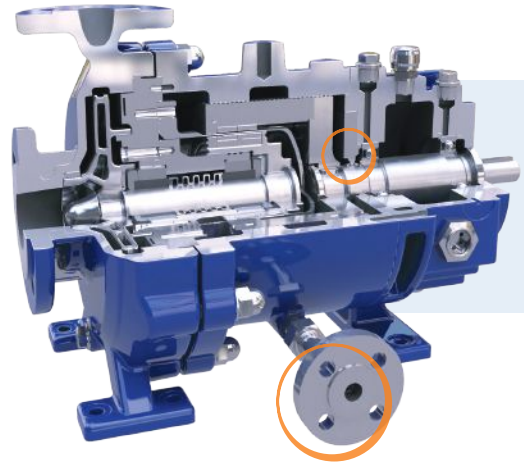

SECONDARY CONTAINMENT SYSTEM

Over the internal containment shell an outside secondary containment shell in special configuration is located, to provide full secondary containment, which allows a higher pressure with the same wall thickness. This design is in accordance with API 685. To guarantee the leak tightness of the system a vacuum is created between the two cans, which can be controlled by a pressure monitoring. If the containment shell is damaged from outside atmosphere pressure can be indicated, if the containment shell is damaged from inside system pressure can be indicated.

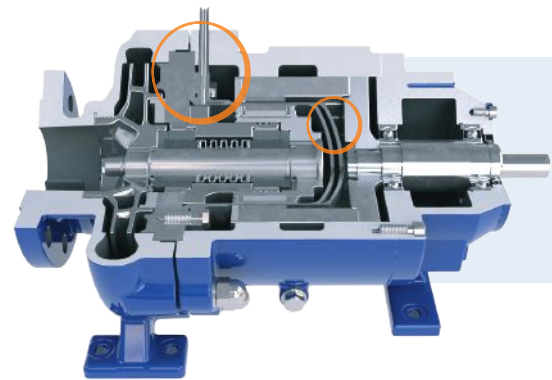

Z - CERAMIC ZIRCONIUM OXIDE CONTAINMENT SHELL

By using a non-metallic containment shell, e.g. made of Zirconium Oxide, the magnetic losses are eliminated, therefore the efficiency of the pump is increased significantly. Great energy savings can be achieved, especially at high pump performances. The containment shells made of Zirconium Oxide are designed for a maximum pressure of 40 bar (580 psi) at 120°C and can be used up to an operating temperature of 250°C (482°F). The fastening via locking ring guarantees a trouble free assembly and disassembly, by ensuring the Zirconium Oxide containment shell flange is only subject to optimum compressive stress.

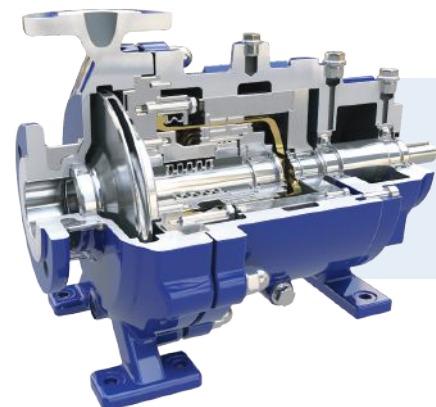

F1 - MAIN STREAM FILTER

The main stream filter is assembled on the discharge flange of the pump. In case of a solid containing mainstream, clean fluid is provided for the internal flows to the journal bearings and the magnetic drive for lubrication and cooling. The main stream filter is self cleaning. The internal flows can be measured by pressure and flow monitoring.



H1 AND H2 - CASING AND INTERMEDIATE HOUSING HEATING

The pumps can be equipped with a heating jacket at the casing (H1) and/or at the intermediate housing (H2). Both heated areas can be operated independently, or can be connected with a bypass-pipeline. The heating jackets are designed as standard for 16 bar (232 psi) at 200°C (392°F) (steam) or for 6 bar (87 psi) at 350°C (662°F) (heat transfer oil). Both heated areas can also be used for cooling.

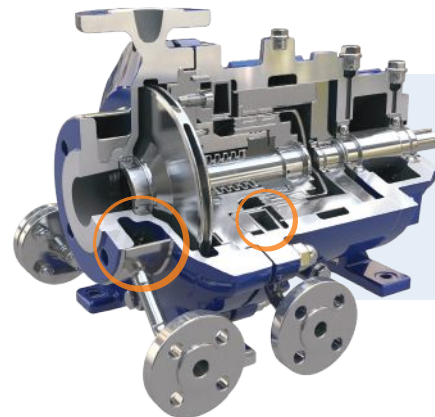

E1 AND E2 - EXTERNAL FLUSHING LUBRICATION

The main stream filter is assembled on the discharge flange of the pump. In case of a solid containing mainstream, clean fluid is provided for the internal flows to the journal bearings and the magnetic drive for lubrication and cooling. The main stream filter is self cleaning. The internal flows can be measured by pressure and flow monitoring.



INDUCER

At very low NPSHa values the values for the NPSHr pump can be significantly reduced by use of an inducer. Hereby the pump characteristic will not be changed. A later assembly in the pump is normally possible without major modifications.



CRP-M

Centrifugal Pump with Permanent Magnetic Drive

Performance Range

SELECTION CHART CRP-M

n=3500

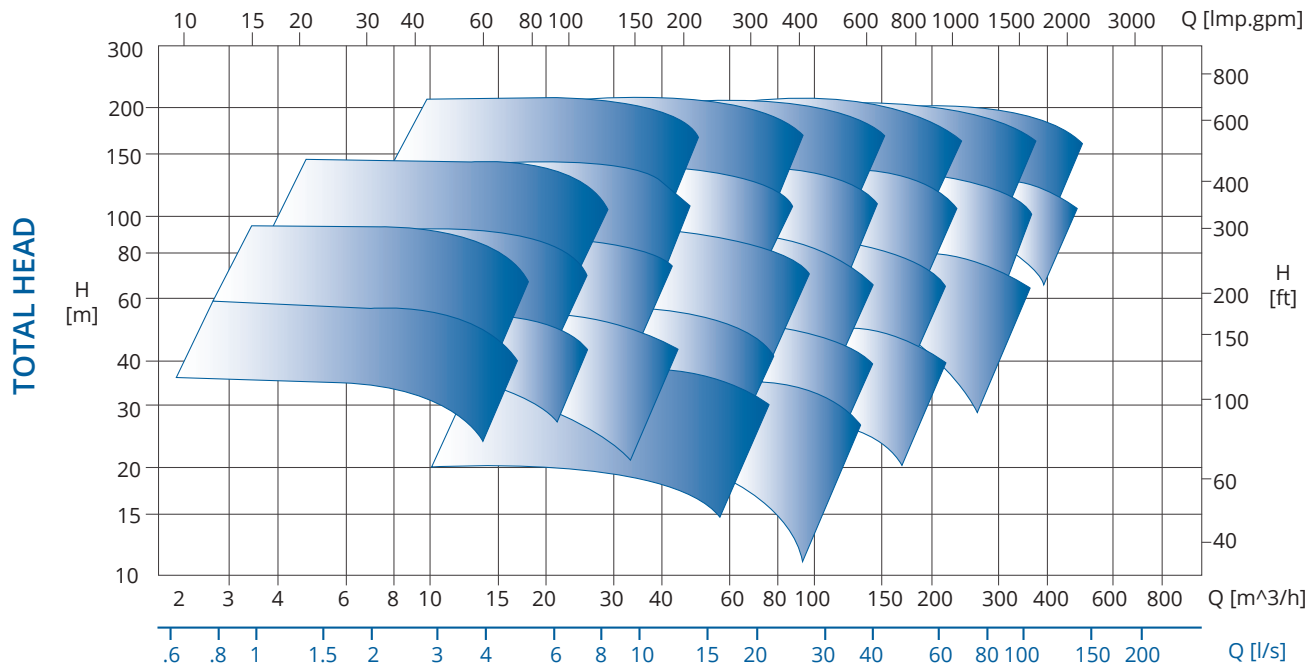

SELECTION CHART CRP-M

n=1450

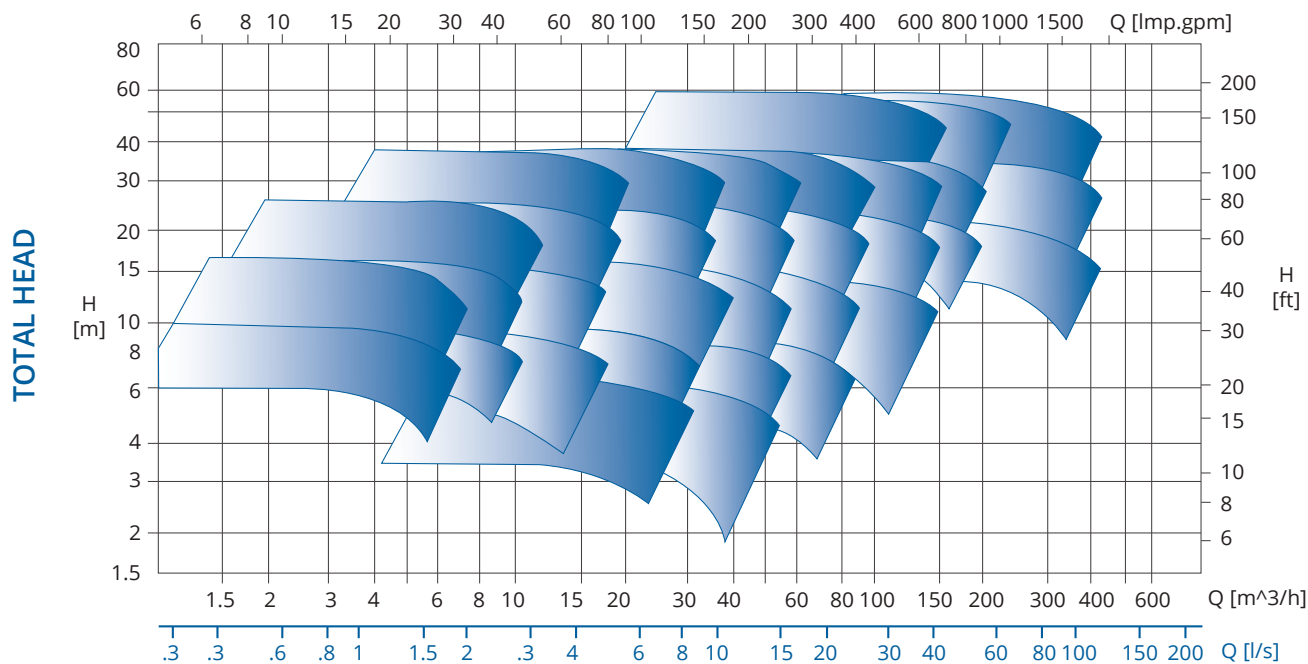

SELECTION CHART CRP-M

n=1750

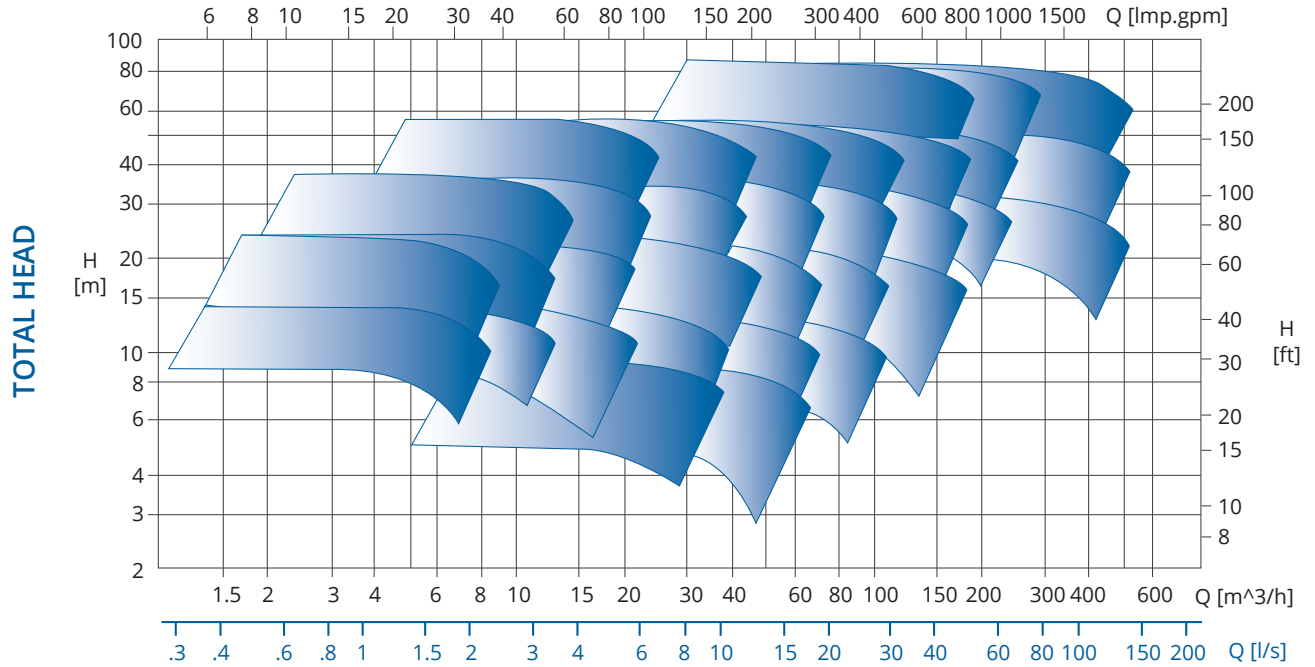

SELECTION CHART CRP-M

n=2900

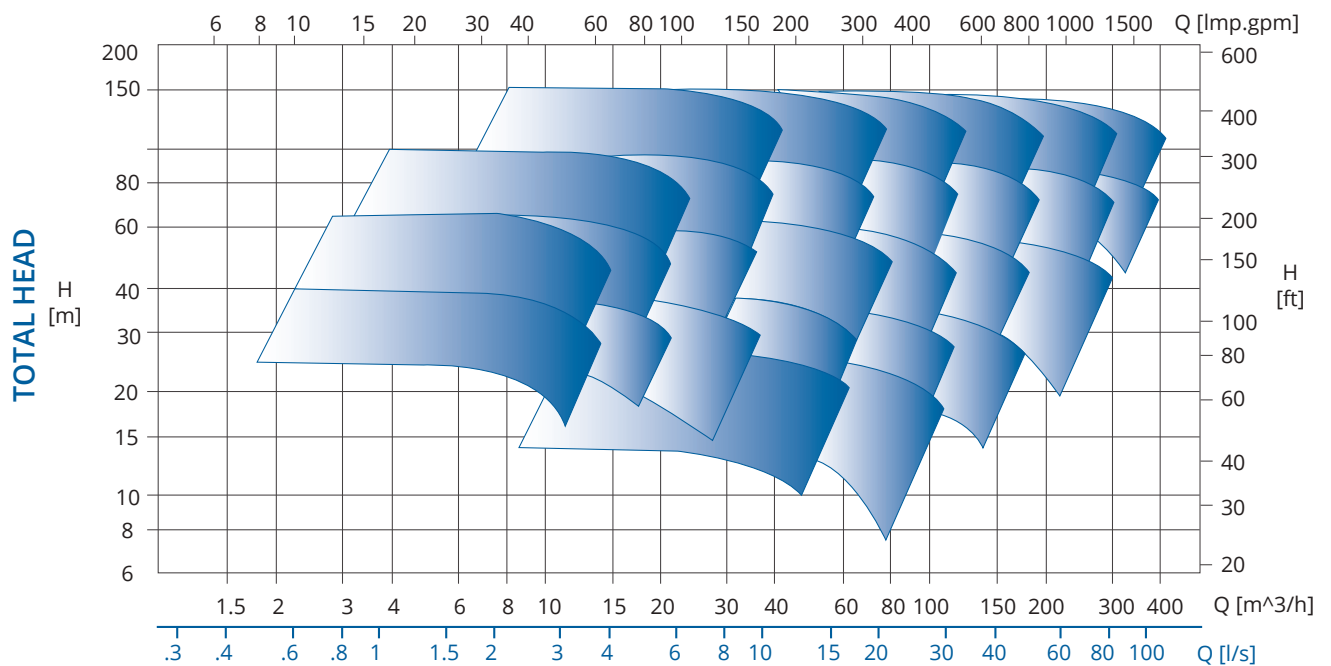









+75 years creating the pumping technology that moves our world

Ruhrpumpen is an innovative and efficient pump technology company that offers highly-engineered and standard pumping solutions for the oil & gas, power generation, industrial, water and chemical markets. We offer a broad range of centrifugal and reciprocating pumps that meet and exceed the requirements of the most demanding quality specifications and industry standards such as API, ANSI, UL, FM, ISO and Hydraulic Institute.



Ruhrpumpen Plants

-  ARGENTINA, Buenos Aires
-  BRAZIL, Rio de Janeiro
-  CHINA, Changzhou
-  EGYPT, Suez
-  GERMANY, Witten
-  INDIA, Chennai
-  MEXICO, Monterrey
-  UK, Lancing
-  USA, Tulsa

-  *Manufacturing plant & service center*
-  *Service center*