



Specialist for Pumping Technology



GWP
Self Priming Pump

+75 years developing the pumping technology that drives progress

Ruhrpumpen is an innovative and efficient pump technology company that offers highly engineered, custom made solutions for oil & gas, chemical processing, power generation, industrial applications and water.

Implementation of cutting-edge technology and world-class engineering, combined with our unique vertically integrated structure, allows Ruhrpumpen to design complex technical solutions, creating the most robust and powerful pump systems in the marketplace.

Our broad product line complies with the most demanding quality standards and industry specifications such as **American Petroleum Institute (API), American National Standards Institute (ANSI), Underwriter's Laboratories (UL), Factory Mutual (FM), National Fire Protection Association (NFPA), ISO and Hydraulic Institute.**

Products Include:

- Single stage overhung pumps
- Vertical in-line pumps
- Single and multi-stage between bearing pumps
- Multi-stage vertical pumps
- Reciprocating plunger pumps
- Sealless magnetic drive pumps
- Fire protection systems
- Pitot tube pumps
- Hydraulic decoking systems
- Horizontal pumping systems



Ruhrpumpen is your single source supplier

- Original Equipment
- Spare parts
- Installation and startup support
- Repair and maintenance
- Engineering, training and consulting
- Reverse engineering

Benefits of our pumps

- Proven reliability
- High efficiency designs ensure lowest operating cost
- Robust design allows for long system life with minimal maintenance
- Optimized total cost of ownership

GWP Pump

The GWP is a self-priming pump model that can handle both clear liquids and suspended solids up to 3" in diameter.

It's design has a chamber with permanent oil bath for the mechanical seal, allowing it to work "dry" indefinitely.

Our GWP centrifugal pumps are installed with a self-priming system, coupled to a diesel or electric motor.

These design features make our GWP pumps the perfect choice for construction, municipal and industrial applications; such as general sewage, wastewater and providing solutions to the most challenging needs in the industry.

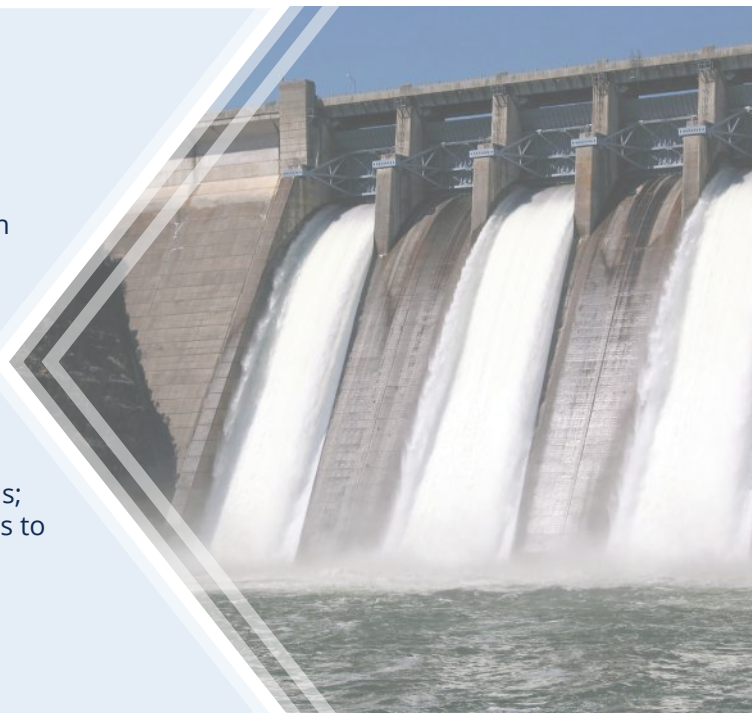

Sectional View

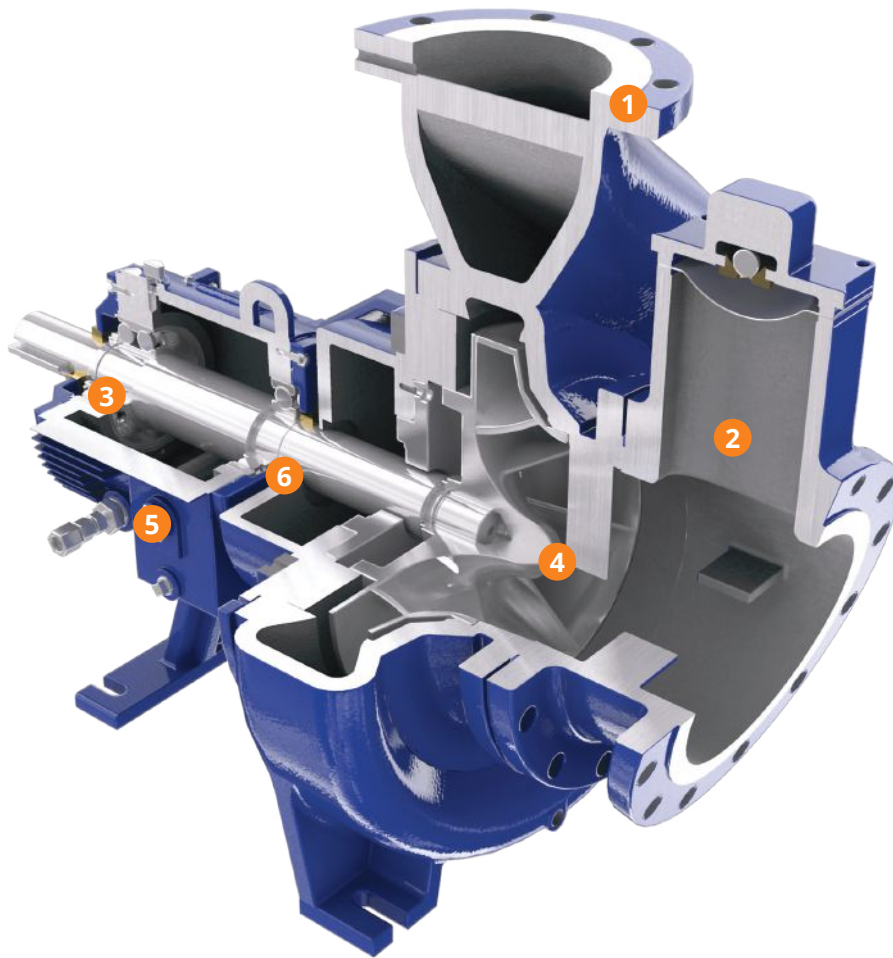

- 1** ANSI 150 or 300 flange drilling is available based on material selection. RF or FF designs are available based on requirements.
- 2** Self-priming system.
- 3** Double row thrust bearing provides minimal shaft end play for extended mechanical seal life.
- 4** Enclosed impeller design.
- 5** Oversized oil sight glass mounted on both sides of the bearing unit.
- 6** Standard Inpro/Seal® bearing insulators.

Dimensions

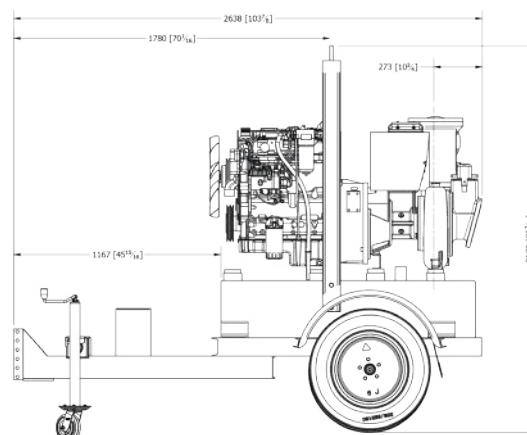
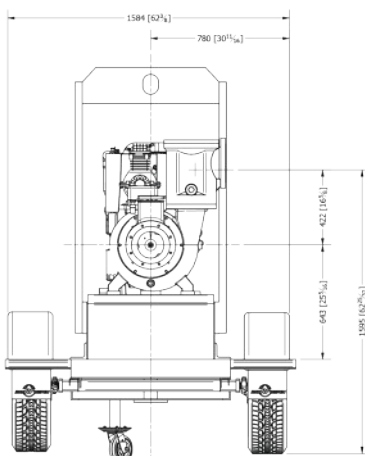

Simplify your installation with our wide range of accessories

Suction	<p>Industrial Hose</p> <ul style="list-style-type: none"> Can be assembled with ANSI B16.5 flanges or type Bauer flanges. 	
	<p>Flat water discharge hose for general use</p> <ul style="list-style-type: none"> These hoses are generally delivered in 15 m sections, except for specific operations, and can be assembled as requested. The holed up flanges are Bauer type. 	
Discharge	<p>Flat discharge hose for fracking</p> <ul style="list-style-type: none"> 100 m rolls available from 6" to 8". 200 m rolls available from 12". The rolls come with quick aluminum couplings; the sections are spliced together with Vitaulic type clamps. 	
	<p>Quick female Bauer-type coupling for suction and discharge hose</p> <ul style="list-style-type: none"> Male/Female couplings used for the ends of suction hoses and flat discharge hoses (cannot be used for fracking discharge hoses). Available from 6" to 8". 	
Couplings	<p>Quick male Bauer-type coupling for suction and discharge hose</p> <ul style="list-style-type: none"> Male/Female couplings used for the ends of suction hoses and flat discharge hoses (cannot be used for fracking discharge hoses). Available from 6" to 8". 	
	<p>Secure leveler for Bauer-type Couplings</p> <ul style="list-style-type: none"> Male/Female couplings used for the ends of suction hoses and flat discharge hoses (cannot be used for fracking discharge hoses). Available from 6" to 8". 	
	<p>O-Ring NVR for Female Bauer-type Couplings</p> <ul style="list-style-type: none"> Male/Female couplings used for the ends of suction hoses and flat discharge hoses (cannot be used for fracking discharge hoses). Available from 6" to 8". 	

Male Coupling with ANSI B16.5 flange

- They are installed in the pump's suction and discharge.
- Available from 6" to 8".



Female Coupling with ANSI B16.5 flange

- They are installed in the pump's suction and discharge.
- Available from 6" to 8".



Coupling for flat hose with Vitaulic groove

- Used in flat hoses for high pressure, generally used in mining and fracking.
- Available from 6" to 8".

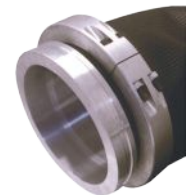

Vitaulic Clamp

- Used in flat hoses for high pressure, generally used in mining and fracking.
- Available from 6" to 8".



O-Ring Vitaulic Clamp

- Available from 6" to 8".



Secure leveler for Bauer-type Couplings

- Male/Female couplings used for the ends of suction hoses and flat discharge hoses (cannot be used for fracking discharge hoses)
- Available from 6" to 8"



O-Ring NVR for Female Bauer-type Couplings

- Male/Female couplings used for the ends of suction hoses and flat discharge hoses (cannot be used for fracking discharge hoses)
- Available from 6" to 8"











+75 years creating the pumping technology that moves our world

Ruhrpumpen is an innovative and efficient pump technology company that offers highly-engineered and standard pumping solutions for the oil & gas, power generation, industrial, water and chemical markets. We offer a broad range of centrifugal and reciprocating pumps that meet and exceed the requirements of the most demanding quality specifications and industry standards such as API, ANSI, UL, FM, ISO and Hydraulic Institute.



Ruhrpumpen Plants

-  ARGENTINA, Buenos Aires
-  BRAZIL, Rio de Janeiro
-  CHINA, Changzhou
-  EGYPT, Suez
-  GERMANY, Witten
-  INDIA, Chennai
-  MEXICO, Monterrey
-  UK, Lancing
-  USA, Tulsa

-  *Manufacturing plant & service center*
-  *Service center*