



Specialist for Pumping Technology



ZM I TO III

**Axially Split Case, Heavy Duty API 610
Process Pump (BB1)**

ZM I TO III

Axially Split Case, Heavy Duty API 610 Process Pump (BB1)

+75 years developing the pumping technology that drives progress

Ruhrpumpen is an innovative and efficient pump technology company that offers highly engineered, custom made solutions for oil & gas, chemical processing, power generation, industrial applications and water.

Implementation of cutting-edge technology and world-class engineering, combined with our unique vertically integrated structure, allows Ruhrpumpen to design complex technical solutions, creating the most robust and powerful pump systems in the marketplace.

Our broad product line complies with the most demanding quality standards and industry specifications such as **American Petroleum Institute (API)**, **American National Standards Institute (ANSI)**, **Underwriter's Laboratories (UL)**, **Factory Mutual (FM)**, **National Fire Protection Association (NFPA)**, **ISO** and **Hydraulic Institute**.

Products Include:

- Single stage overhung pumps
- Vertical in-line pumps
- Single and multi-stage between bearing pumps
- Multi-stage vertical pumps
- Reciprocating plunger pumps
- Sealless magnetic drive pumps
- Fire protection systems
- Pitot tube pumps
- Hydraulic decoking systems
- Horizontal pumping systems



Ruhrpumpen is your single source supplier

- Original Equipment
- Spare parts
- Installation and startup support
- Repair and maintenance
- Engineering, training and consulting
- Reverse engineering

Benefits of our pumps

- Proven reliability
- High efficiency designs ensure lowest operating cost
- Robust design allows for long system life with minimal maintenance
- Optimized total cost of ownership



ZM I-III Pumps

The process and transfer pump of ZM design was developed for the tough demands of the pipeline and process industry mainly pumping:

- Crude oil
- Oil
- Liquid hydrocarbons

But also suitable for pumping:

- Cooling water
- Hot water
- River water
- Brackish water
- Sea water
- Chemical solutions

This design is also used for loading in tank farms and as fire-fighting pump in fire-protection systems.

Additionally, pumps ZM I-III run successfully in following services:

- Oil-extraction technology, onshore and offshore
- Pipeline technology
- Refinery technology
- Chemical / petrochemical industry
- General industry
- Metallurgical and steel industries
- Combined heating
- Power stations

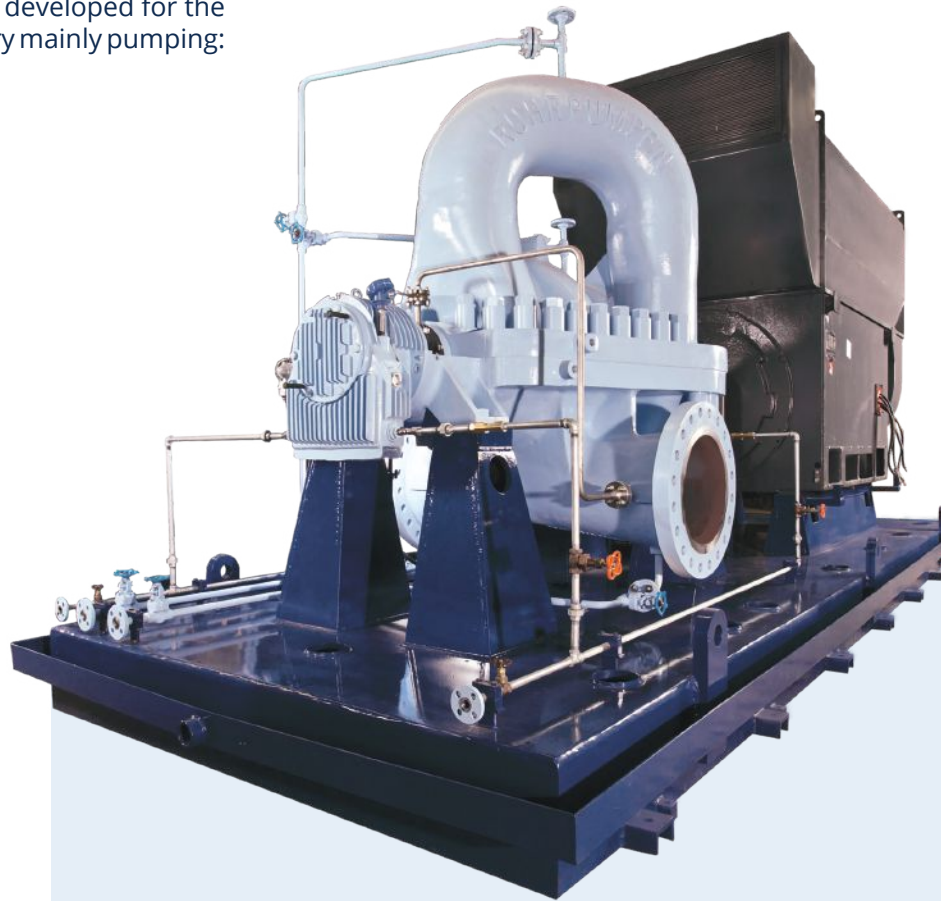

Higher speeds and heads on request

The program comprises 60 standard sizes with only 9 bearing assemblies which can be operated at the speeds given in the selection charts. Other speeds and special sizes on request.

The program is built according to the latest status of hydrodynamic and mechanical design. It is characterised by the use of robust, proven and modular design elements in order to reduce the number of individual parts.

According to its intended use, this program is manufactured to stringent quality demands. A proven quality assurance system guarantees compliance with all specifications for design, material procurement, processing, assembly, testing, and documentation.

The design and manufacturing is carried out according to the latest edition of API 610.

Adaption to other specifications is possible.

Derivates from ZM-Type

ZLM

Axially split, diffuser type, single stage pump; other features are the same as ZM model.

The diffuser type allows later modification of the pumps conditions of service with a minimum of site service efforts and costs.

ZLM

Axially split, double volute casing, two stage pump, first-stage impeller is double suction for critical NPSH application.

Suction- and discharge connections are also side-side arrangement but offset.

ZM I TO III

Axially Split Case, Heavy Duty API 610 Process Pump (BB1)

Performance Range

ZM I

Selection Chart ZM I

2 POLES
50 Hz 60 Hz

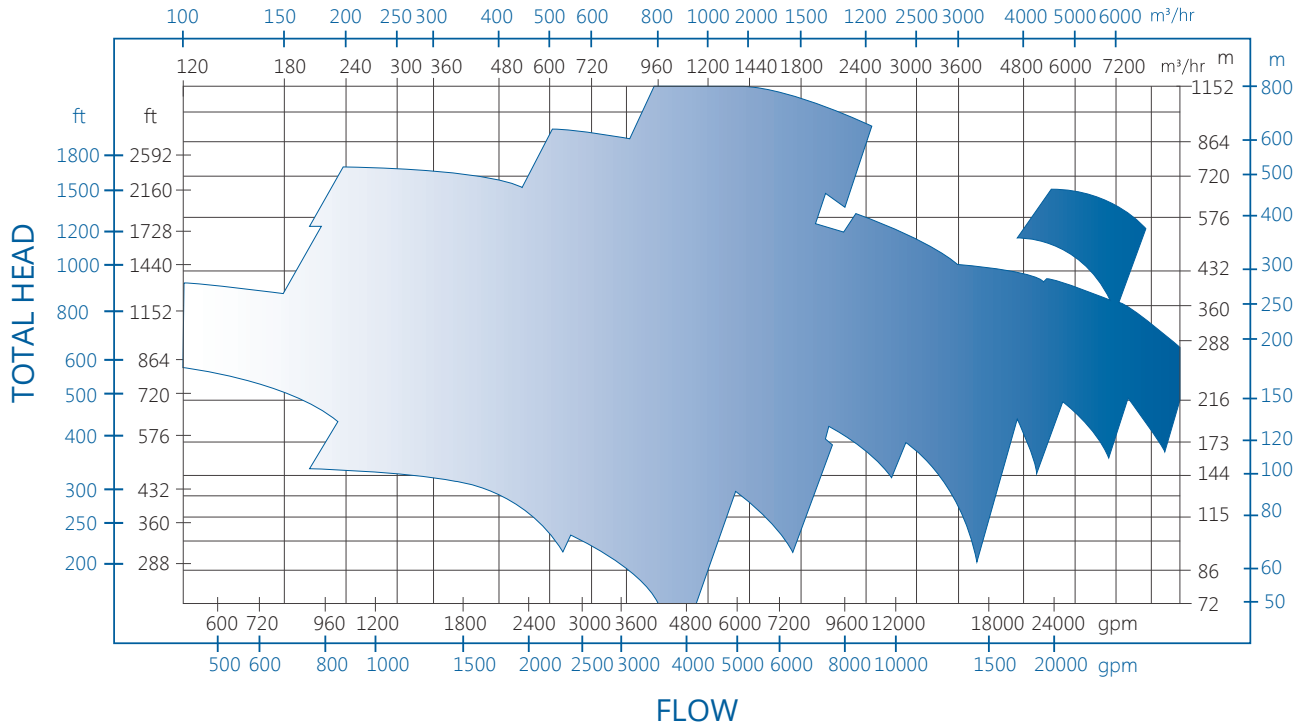

ZM II

Selection Chart ZM II

4 POLES
- 50 HZ - 60 HZ

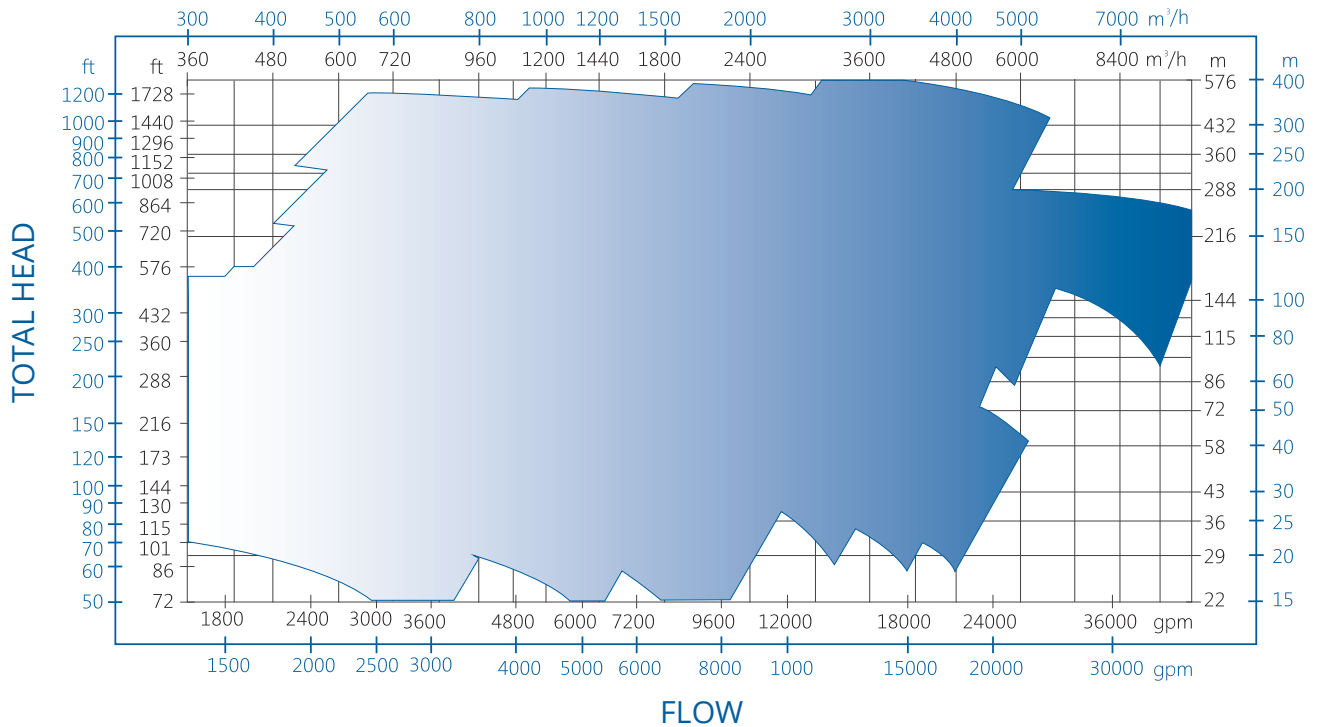

ZM III

Selection Chart ZM III

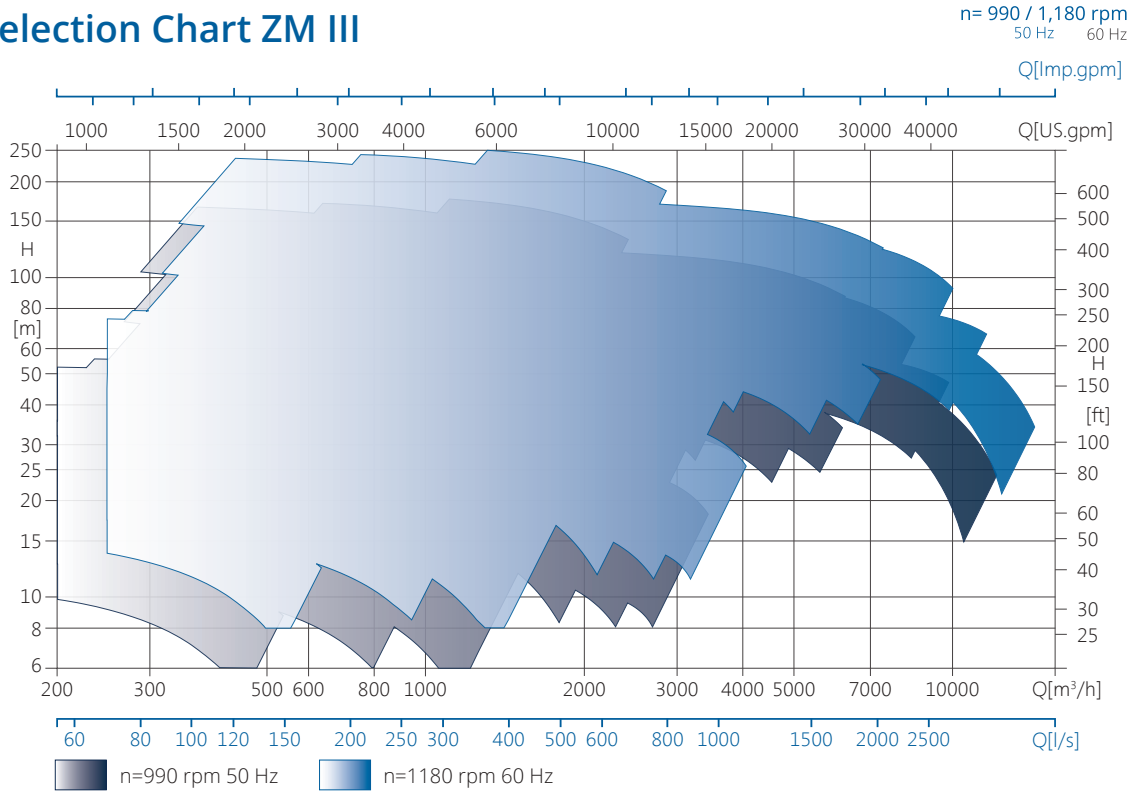

ZM IV

Selection Chart ZM IV

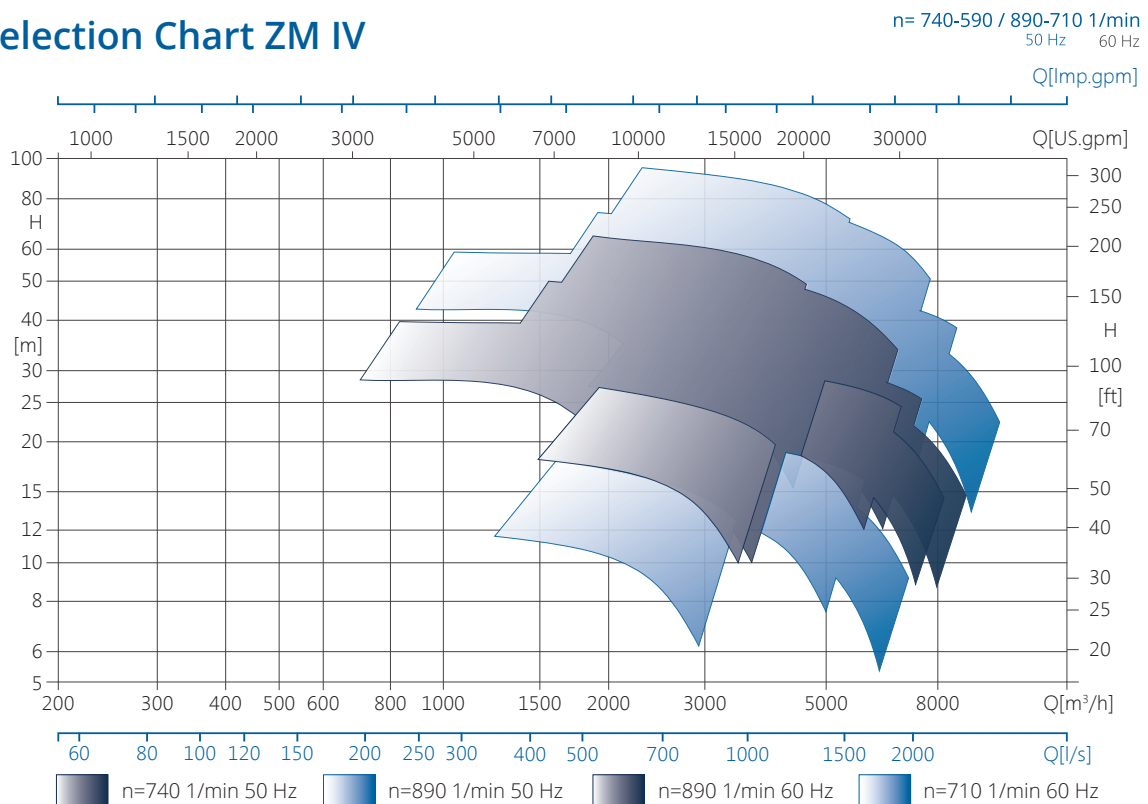

Characteristics and Design Features

- 1** 60 pump sizes with axially split, foot mounted casings are available. Alternatively it is possible to install the casings in near centerline position. Suction and discharge branches are integral part of the lower half casing. Discharge flange diameter from 150 to 800 mm. Design for clock-wise or counter clockwise direction of rotation is possible. ZMS: Standard is near centerline mounted.
- 2** All flange designs, e.g. according to DIN 2501/ISO 2084, ASME B16.5 or BS, are possible. All material designs according to DIN/ISO, ASME and BS can be supplied. Special materials on request.
- 3** Pump casing design from 10 to 40 bar, depending on the size. The test pressure is 1.5 times the max. allowable working pressure. Temperature of the liquid from -10 to +200°C. Other pressures and temperatures are available on special request. ZMS: Design pressures for ZMS pumps up to 100 bar.
- 4** Amply dimensioned stuffingbox chambers for the installation of all commercially available mechanical seals.
- 5** Shaft ends on driver side are usually tapered 1:10 for diameters > 60mm. For hydraulic fits oil holes and grooves are furnished to facilitate disassembly of hubs and bearings.
- 6** The pump casing is split in the horizontal plane. The upper and lower casing half are sealed by an asbestos-free gasket and are connected using stud bolts and cap nuts.
- 7** The adequately dimensioned pump shaft guarantees minimum rotor deflection.
- 8** ZM pumps are equipped with antifriction bearings that are grease or ring-oil lubricated. Single piece bearing housing with the possibility of cooling. ZMS: Standard are hydrodynamic bearings. Standard is a forced tilting pad bearing.
- 9** The thrust bearing assembly is located on the non driven side of the pump. Any possible axial forces are absorbed in both directions by a pair of angular contact ball bearings. ZMS: Standard is a forced fed tilting pad bearing.
- 10** For heavy duty designs, the thrust bearing assembly is offered as tilting pad bearings while the radial bearings are changed to sleeve bearings. In this respect, an appropriate oil installation will be provided for the oil supply and for the cooling. Designs with a gear pump flanged to the pump shaft and/or with an oil pump driven by an electric motor are possible. Oil units according to manufacturer standard or to API 614 will be supplied if required.
- 11** The suction and discharge branches of the pump are cast on each side of the lower part of the pump casing. Thus, the upper part of the casing and the rotor are easy to dismantle.
- 12** The pressure containing parts are subjected to comprehensive quality control. Tests are performed not only in the foundry but also at our company and are confirmed with certificates. On our test bed, the casing is tested at 1.5 times the max. allowable working pressure. The corrosion allowance of the wall thickness of the casings and casing covers is min. 3.2 mm.
- 13** Drain connections are provided at the lowest points of the pump casing. Drain connections can be screwed, welded or flanged. It is possible to install different kind of valves.
- 14** A vent connection is provided at the highest point of the double volute. Vent connections can be screwed, welded or flanged. It is possible to install different kind of valves.
- 15** Oil-rings are provided to supply lube oil to the anti-friction and/or the sleeve bearings respectively the oil level in the bearing housing is controlled by constant-level-oilers.
- 16** The impellers are double suction type and thus axial thrusts are minimal. The execution with double suction impeller guarantees low NPSHR levels. Impellers in cast-steel design are casted by ceramic-core process. This results in an optimum surface structure. The impellers are dynamically balanced in two planes.
- 17** Replaceable impeller wear rings and casing wear rings with a hardness difference of min. 50HB. The clearance corresponds to the requirements of API 610 (latest edition).
- 18** Pump casing with double volute. Due to this fact, the radial forces are as low as possible. ZLM Pump with diffuser.

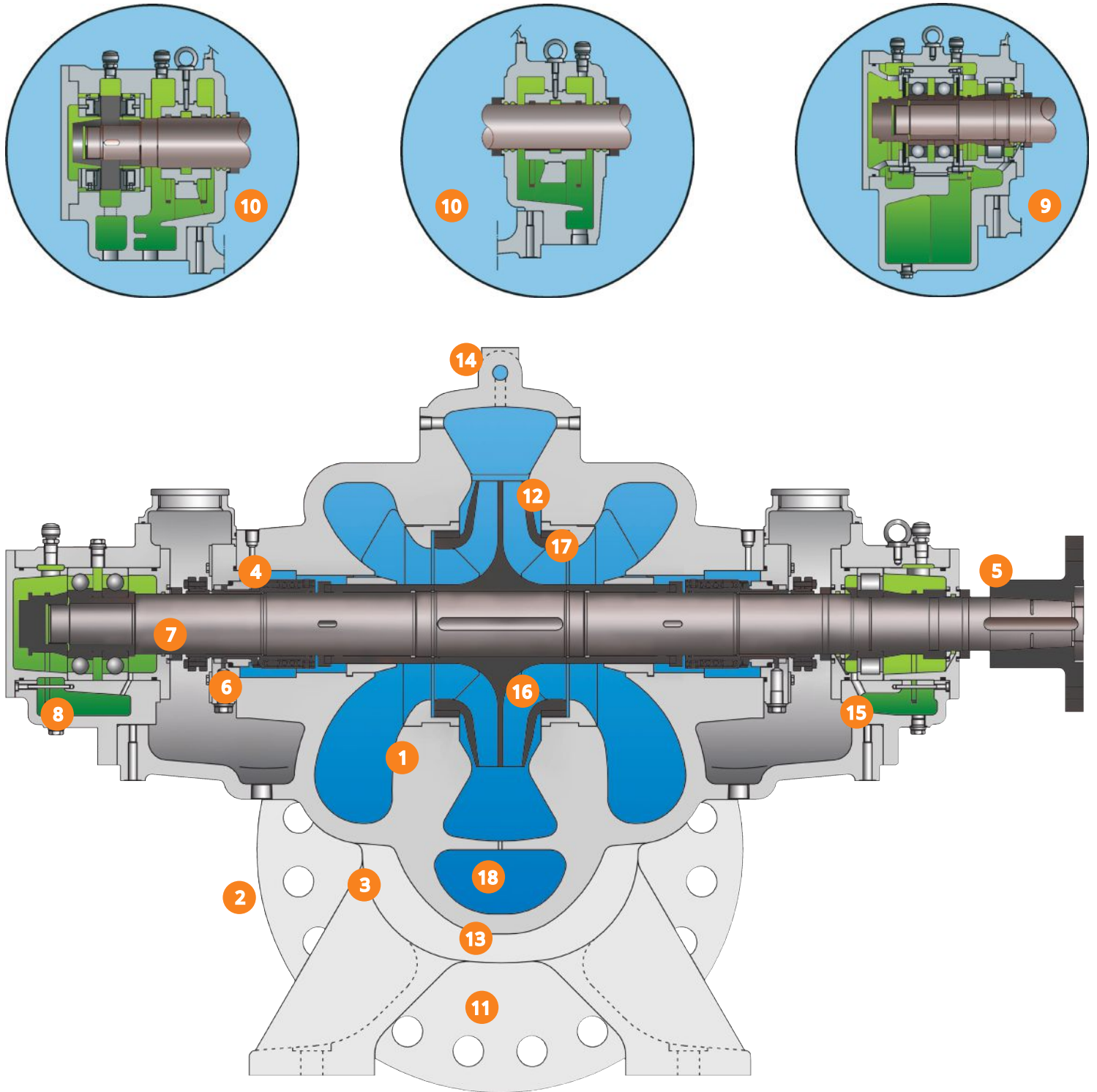

ZM I TO III

Axially Split Case, Heavy Duty API 610 Process Pump (BB1)

Construction

Casings

Axially split, single stage double volute casings with suction and discharge branches arranged side-side in the bottom part. The standard casing is foot mounted. For higher temperatures, the feet are arranged in the near of the centerline of the shaft.

All pump casings are sealed safely with a flat gasket at the partial-flange and are bolted together using stud bolts and cap nuts.

All pump casings are equipped with double volutes to reduce radial forces. The suction chambers are generously designed and hydrodynamically optimized to guarantee low NPSH-values.

Heavy bearing arms are integrally casted to the bottom casing part.

The pump casings are designed to be symmetrical to the centre of the volute. By turning the rotor it is possible to change the drive side and thus the rotation direction.

Pump Test Pressure

The casings are tested at 1.5 times the value of the maximum discharge pressure. Higher test pressures on special request.

Flanges

Flange-connecting dimensions according to ASME B 16.5, alternatively according to DIN 2501/ISO 7005. Other Flange designs are possible.

Material Comparison List

Material	German standard	Material no.	American standard	British standard
Cast Iron GJL-250	EN 1561	JL 1040	ASTM A 48-40B	GJL-250 EN 1561
Steel C45	EN 10083	1.0503	ASTM A 576-1045	C45 EN 10083
Steel 42CrMo4	EN 10083	1.7225	ASTM A 322-4140	42CrMo4 EN 10083
Carbon Steel GP240GH+N	EN 10213	1.0619	ASTM A 216-WCB	GP240GH+N EN 10213
Cast Chrome Steel GX20Cr14	SEW 410	1.4027	ASTM A 743-CA 40	BS3146/2-ANC 1
Cast Chrome Steel GX120CrMo29-2	SEW 410	1.4138	ASTM A 743 Grade CC-50 (equal to)	BS 452 C11 (equal to)
Chrome Nickel Steel X2CrNiMoN22-5-3	EN 10088	1.4462	ASTM A 276-XM-26	X2CrNiMoN22-5-3 EN 10088
Cast Chrome Nickel Steel GX40CrNi27-4	SEW 410	1.4340	ASTM A 743 Grade CC-50	BS 452 C11
Cast Chrome Nickel Steel GX7CrNiMo12-1	EN 10283	1.4008	ASTM A 217-CA15	GX7CrNiMo12-1 EN 10283

In special cases GS12CrMo 19-5

In special cases GP240GH+QT

Other materials on request

Material Table

Part-No. Description		Standard-design I-1	with Cast Chrome Steel Impeller S-6	in Chrome Steel C-6
105	Casing ZM I ZM II ZM III	Cast Iron GJL-250/ Carbon Steel GP240GH+N Cast Iron GJL-250	Carbon Steel GP240GH+N Carbon Steel GP240GH+N	Cast Chrome Nickel Steel GX7CrNiMo12-1 Cast Chrome Nickel Steel GX7CrNiMo12-1
211	Pump shaft	Steel 42CrMo4	Steel 42CrMo4	Chrome Nickel Steel X2CrNiMoN22-5-3
234	Impeller	Cast Iron GJL-250/ Carbon Steel GP240GH+N	Cast Chrome Steel GX7CrNiMo12-1	Cast Chrome Nickel Steel GX7CrNiMo12-1
350	Bearing housing	Cast Chrome Steel GP240GH+N/Cast Iron GJL-250		
433	Mechanical seal	Cast Chrome Steel/Carbon		Silicium Carbide/Silicium Carbide
502	Case wear ring	Cast Iron GJL-250	Cast Chrome Steel GX20Cr14	Cast Chrome Steel GX20Cr14
503	Impeller ring	Cast Iron GJL-250	Cast Chrome Steel GX120CrMo29-2	Cast Chrome Steel GX120CrMo29-2
922	Impeller nut	Cast Chrome Steel GX20Cr14		Cast Chrome Nickel Steel GX40CrNi27-4
923	Bearing nut	Steel C45		

* For pressure-retaining parts. For impellers, ASTM A 743-CA 15 applies, among others.

Casing Materials

API Standard Design:

- ZM I/ZMS Cast steel, GP240GH+N
- ZM II/Z(L)M Cast iron, GJL-250
- ZM III Z(L)M Cast iron, GJL-250

API Chrome-Steel Design:

ZM I to III

- Cast chrome-nickel steel
- GX7CrNiMo12-1
- Other materials on request.

Wear Rings

ZM pumps are equipped with replaceable casing wear rings carried out as angle rings in the volute casing. Impellers have integral wear faces. Impeller wear rings on special request. The clearances of the wear rings meet the requirements specified in the latest edition of API 610.

Impeller

The impeller is designed as a double suction, closed impeller which is cast as one piece and has integral wear faces on both sides of the impeller.

The impellers are dynamically balanced in two planes to grade 2,5.

In order to extend the area of application and to save energy costs, partial load or overload impellers can also be used in addition to the basic impellers. Adaption to changed operating conditions can be achieved by using these impellers. The hydraulics of the ZM pumps are designed and built in accordance with the latest level of knowledge. Low NPSH values combined with moderate suction specific speed guarantee trouble free operation even under severe suction conditions.

ZMS: The suction impeller is double suction while the discharge impeller is only single suction.



ZM I TO III

Axially Split Case, Heavy Duty API 610 Process Pump (BB1)

Construction

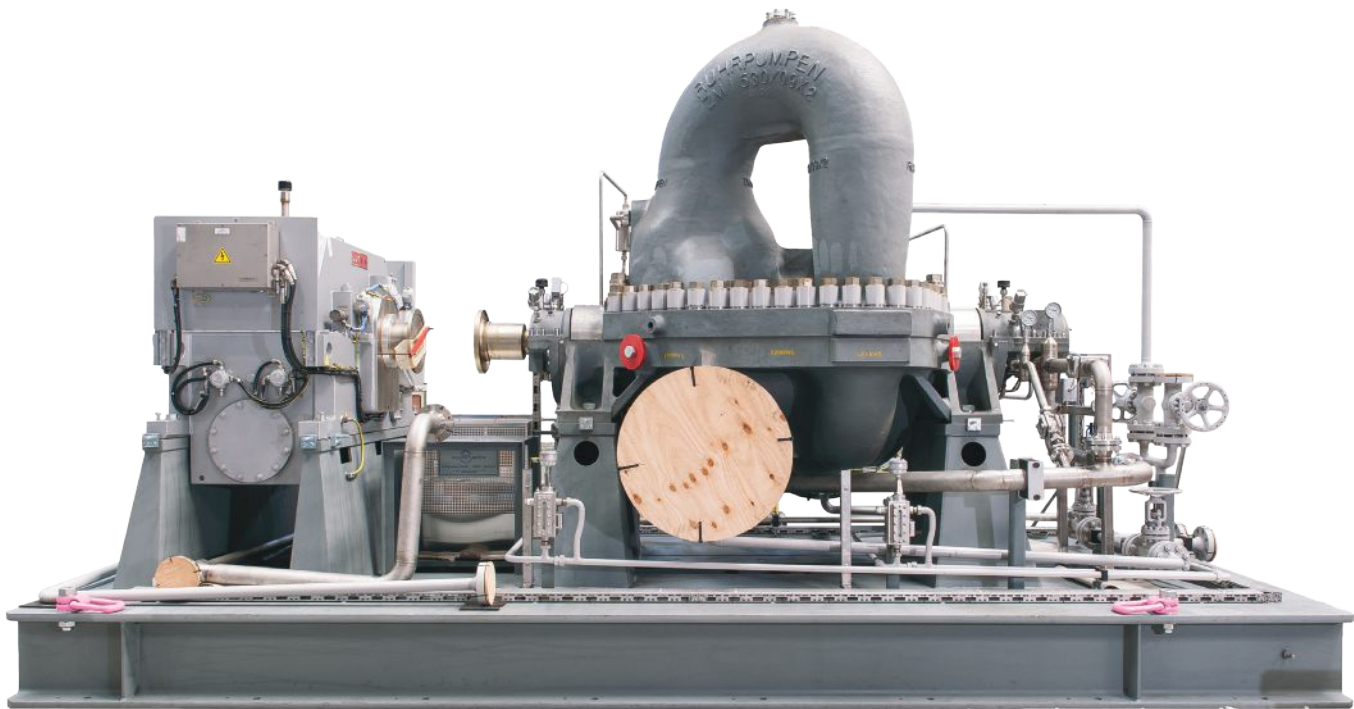

Bearing Assembly

ZM pumps are equipped with The amply dimensioned shafts of ZM pumps result in a very low deflection at critical points of the rotor. The values are well below the units given in the latest edition of API 610.

Due to the tough, high torque shaft design the critical speeds are considerably higher than the operating speed. Rotors are dynamically balanced to grade 2,5.

The powerfully designed shafts of the standard design are located in amply dimensioned antifriction bearings with oil-ring lubrication. Alternatively, a design with sleeve bearings can be supplied as well. The bearing design depends on the size of the pump and the pump speed. The 180° bearing arms are cast on the pump casing and accommodate the flanged bearing housings. Labyrinth rings protect the bearings from the entry of dust and water from outside. Wherever

necessary, the bearing housings are supplied with cooling. For outdoor installation, the space between pump casing and bearing assembly is sealed by a hood.

ZMS: The ZMS pumps are only available with hydrodynamic bearings.

Shaft Sealing

Subject to agreement, the pumps are equipped with balanced or unbalanced single or double mechanical seals. The seal chambers allow all commercially available mechanical seals to be installed. On request, double seals with a barrier liquid and pumping rings can also be supplied.

In order to facilitate the removal of the seals without opening the pump, a cartridge design is provided in conjunction with a removable shaft coupling.

As an alternative, all pumps can be supplied with soft packings. In the area of the stuffing box, the shaft is protected by shaft sleeves.

All the customary material combinations can be used.

Removability

The axial split casing pumps are handled easily during inspection and maintenance. After removing the upper casing half the rotor can be handled without detaching the complete pump from the piping system and baseplate. If a three-piece coupling or a spacer coupling is used, it is not necessary to dismantle the drive motor either.

Coupling and Coupling Ward

Flexible couplings are used as standard.

The coupling guard is manufactured in a nonsparking design, as per standard safety regulations.

Baseplates

The heavy duty baseplates are manufactured from steel as welded structures. The connection to the foundation is made by using foundation bolts. After final alignment the baseplates have to be grouted by using shrink free concrete.

As a standard the baseplates are equipped with a drain pan that extends under all potential leakage sources. The baseplate can be drained by a 1" 150# flange.

Grout-free baseplates can also be supplied on special request.

Direction of Rotation

Viewed from the driver, clockwise or, alternatively, counter clockwise direction of rotation.

Drive

Direct drive via flexible couplings by an electric motor, diesel engine or turbine etc. Variable speed drives can be used. The use of a gearbox or a hydraulic coupling is also possible.

Characteristic Curves

ZM pumps have a stable characteristic-curve shape. The NPSH value available should be at least 10 % higher than the value of NPSH required for the pump. But not lower than 0,5 m.

All the pumps can be operated at a speed deviating from the indicated values. The hydrodynamic values must then be converted according to the laws of affinity. If the speed shall be increased the pump must be checked by the factory.

The design of the pump is based on a kinematic viscosity of 1 mm²/s.

In case of special applications it is always necessary to check pressure and power design limits.



ZM I TO III

Axially Split Case, Heavy Duty API 610 Process Pump (BB1)

Dimensions

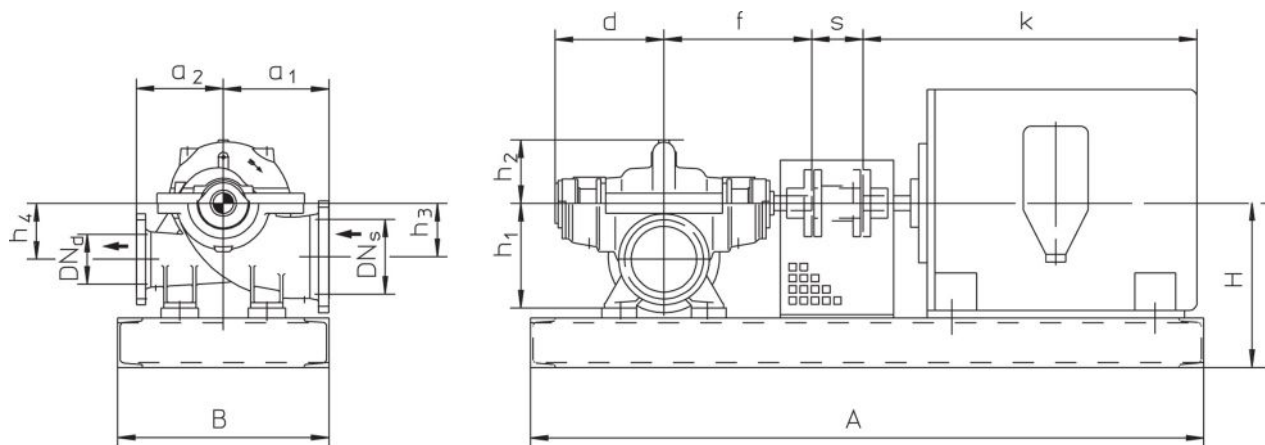

Dimensional Drawing
Pump Unit

PUMP DIMENSIONS ZM I (mm)

Size	DN_s	DN_d	a_1	a_2	d	f	h_1	h_2	h_3	h_4	S^*
325/01	200	150	380	350	450	550	370	370	225	225	200
325/03	300	250	490	440	750	755	550	350	250	250	200
325/04	350 0	300	550	700	620	740	550	330	300	300	20
375/01	300	200	425	420	570	680	400	300	215	250	200
375/03	300	200	500	400	620	755	500	350	280	280	250
375/04	350	300	625	550	640	810	630	380	325	325	250
375/04N	350	300	625	550	800	795	630	420	325	325	250
375/05	400	300	650	540	620	800	650	410	375	335	250
375/06	500	400	750	700	900	930	750	450	360	360	250
375/07	500	400	850	850	970	1000	800	500	400	400	250
400/03	200	150	470	410	460	550	400	300	225	275	160
440/03	300	200	600	520	880	780	550	380	300	300	250
440/05	350	300	650	550	850	865	680	420	320	360	250
440/08sp	600	450	825	1010	1040	1045	850	580	480	480	250
480/07	500	400	750	750	1000	1015	850	600	400	400	250
480/08	600	500	1200	1000	1010	1040	845	480	480	480	300
480/08sp	600	500	1200	1000	1010	1040	845	480	480	480	300
480/09	700	500	1000	1000	1040	1080	1050	600	555	495	300

All dimensions are not obligatory.

Pump Dimensions ZM II in mm											
Size	DN _s	DN _d	a ₁	a ₂	d	f	h ₁	h ₂	h ₃	h ₄	S*
275/02	300	250	500	420	510	600	490	300	290	285	160
375/04	400	350	575	450	510	600	610	375	325	375	160
325/02	300	250	500	430	510	600	490	310	252	295	160
325/04	400	300 0	530	450	510	600	570	330	325	325	160
325/05	400	350	650	600	610	740	630	410	330	375	200
375/00	200	150	450	390	460	540	400	290	225	275	160
375/01	300	250	500	485	580	680	480	320	290	300	200
375/02	300	250	500	485	580	680	480	320	290	300	200
375/04	350	300	700	600	600	740	630	395	350	350	200
375/05	500	350	650	600	650	790	630	435	330	390	200
375/06	500	400	800	600	770	885	800	500	400	470	200
375/06N	500	500	810	610	775	885	800	635	400	470	250
375/07	600	500	800	700	770	935	800	500	400	460	200
440/02	300	200	550	480	580	680	480	365	290	325	200
440/03	350	250	600	485	580	680	550	370	320	350	200
440/04	400	300	600	485	600	740	610	410	330	390	200
440/05	500	350	700	600	780	885	700	460	370	430	200
440/06	500	400	810	610	780	885	800	580	400	465	200
530/01	250	200	540	480	580	680	460	390	280	310	200
530/02	300	250	560	540	610	740	500	400	315	325	200
530/03	350	250	620	505	610	740	550	405	320	355	200
530/04	400	300	670	550	610	740	600	425	330	380	200
530/05	400	350	700	600	730	835	660	465	330	445	200
530/06	600	400	805	600	780	940	800	500	400	460	250
530/07	700	500	900	800	890	1130	950	580	460	560	250
630/03	350	250	700	700	670	790	650	480	320	430	200
630/04	400	300	800	800	820	925	680	530	350	460	200
630/05	500	350	820	820	820	1010	800	550	400	480	250
630/06	500	400	900	800	890	1130	900	560	460	500	250
630/08	700	600	1100	1100	1140	1350	1050	850	540	640	350
680/09	800	700	1100	1200	1140	1425	1150	750	620	600	350
750/06	600	400	900	800	1100	1150	850	700	470	520	350

All dimensions are not obligatory.

Pump Dimensions ZM III in mm											
Size	DN _s	DN _d	a ₁	a ₂	d	f	h ₁	h ₂	h ₃	h ₄	S*
375/01	300	250	500	485	580	680	480	320	290	300	200
375/06N	500	500	810	610	775	885	800	635	400	470	250
530/07	700	500	900	800	890	1130	950	580	460	560	250
530/08	700	600	1100	935	1000	1230	1050	660	580	630	250
530/09	800	700	1150	1000	1160	1425	1150	750	650	700	300
580/09	800	800	1250	900	1060	1320	1350	800	800	800	300
630/08	700	600	1100	1100	1000	1230	1050	725	540	640	250
680/09	800	700	1100	1200	1140	1425	1150	750	620	600	350
680/09N	800	700	1200	1000	1220	1430	1250	780	700	700	350
750/08	700	600	1100	1000	1140	1350	1150	800	650	650	350

The outer dimensions of few sizes pumps ZM III are identical with the outer dimensions of pump ZM II.









All dimensions are not obligatory.

+75 years creating the pumping technology that moves our world

Ruhrpumpen is an innovative and efficient pump technology company that offers highly-engineered and standard pumping solutions for the oil & gas, power generation, industrial, water and chemical markets. We offer a broad range of centrifugal and reciprocating pumps that meet and exceed the requirements of the most demanding quality specifications and industry standards such as API, ANSI, UL, FM, ISO and Hydraulic Institute.



Ruhrpumpen Plants

-  ARGENTINA, Buenos Aires
-  BRAZIL, Rio de Janeiro
-  CHINA, Changzhou
-  EGYPT, Suez
-  GERMANY, Witten
-  INDIA, Chennai
-  MEXICO, Monterrey
-  UK, Lancing
-  USA, Tulsa

-  *Manufacturing plant & service center*
-  *Service center*